

AQA

GCSE Physics

New Unit 2

Summary Notes

# Physics Unit 2 Revision (Higher tier)

## Forces

Forces act in pairs. When 2 forces interact they are equal and opposite in direction e.g. a person exerts a force on the chair but the chair applies an equal force upwards on the person, a reaction force.

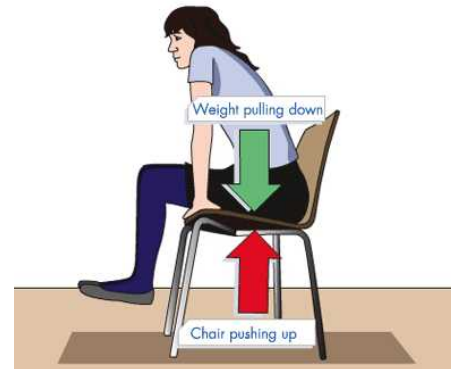

Weight is also a force measured in newtons. Don't confuse mass and weight as mass is actually the amount of 'stuff' that makes up an object measured in kilograms. Weight is the force calculated by

$$\text{Weight (N)} = \text{Mass (kg)} \times \text{Gravitational field strength (N/kg)}$$

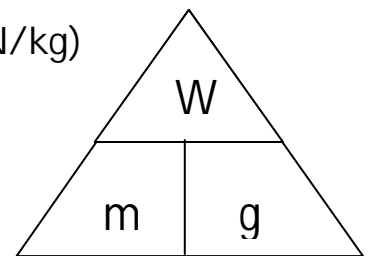

The gravitational field strength on Earth is taken as 10N/kg.

A resultant force is the sum of forces acting on an object.

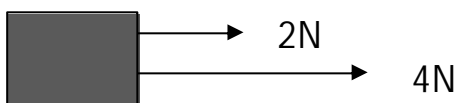

$$\text{Resultant force} = 2\text{N} + 4\text{N} = 6\text{N to the right}$$



$$\text{Resultant force} = 4\text{N} - 2\text{N} = 2\text{N to the right}$$

Balanced forces occur when an object is stationary or moving at a constant speed. The faster an object is moving the bigger the frictional forces acting on it.

$$\text{Resultant Force (N)} = \text{Mass (kg)} \times \text{Acceleration (m/s}^2\text{)}$$

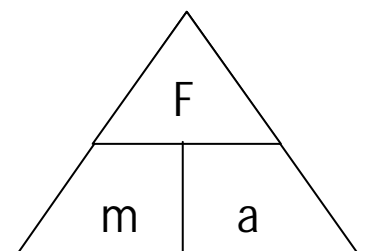

### Sample Question 1

- (a) The diagram shows an aircraft and the horizontal forces acting on it as it moves along a runway. The *resultant force* on the aircraft is zero.

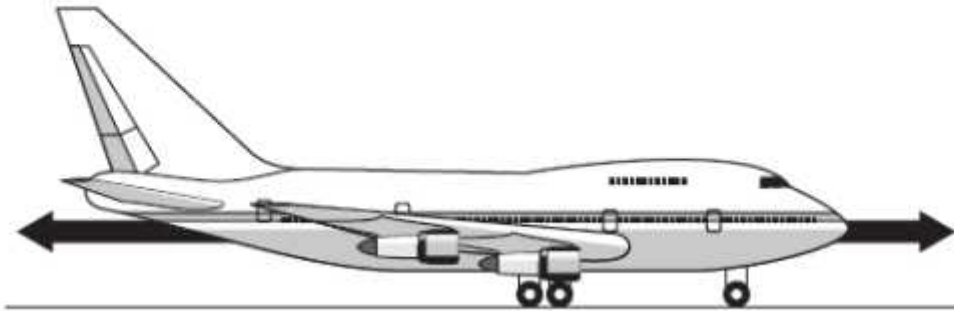

(i) What is meant by the term *resultant force*?

.....  
.....

(1 mark)

(ii) Describe the movement of the aircraft when the resultant force is zero.

.....  
.....

(1 mark)

(b) The aircraft has a take-off mass of 320 000 kg. Each of the 4 engines can produce a maximum force of 240 kN.

Use the equation in the box to calculate the maximum acceleration of the aircraft.

$\text{resultant force} = \text{mass} \times \text{acceleration}$
-------------------------------------------------------------------

Show clearly how you work out your answer and give the unit.

.....  
.....  
.....

Acceleration = .....  
(3 marks)

(c) As the aircraft moves along the runway to take off, its acceleration decreases even though the force from the engines is constant.

Explain why.

.....  
.....  
.....  
.....

(2 marks)

- 7 The arrows in the diagram represent the horizontal forces acting on a motorbike at one moment in time.



- 7 (a) The mass of the motorbike and rider is 275 kg.

Use the equation in the box to calculate the acceleration of the motorbike at this moment in time.

$$\text{resultant force} = \text{mass} \times \text{acceleration}$$

Show clearly how you work out your answer.

.....

.....

.....

.....

.....

Acceleration = .....  $\text{m/s}^2$   
(3 marks)

## Distance-time and velocity-time graphs

Distance-time graphs tell you how an objects distance is changing over time. If there is a smooth slope on your graph then the object is moving at a constant speed. If there is a flat line then there is no movement. A steeper slope means a faster speed. If the slope is downwards the object is returning to the starting position. If there is an

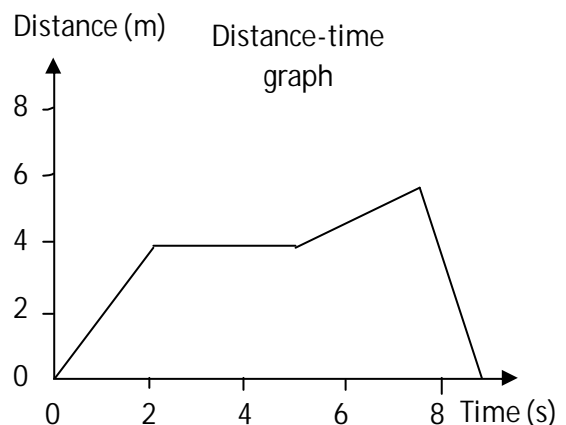

upwards curve ( ) on a distance time graph then the object is accelerating, a downward curve ( ) means it is decelerating.

In order to work out the speed from the slope you choose a section of the slope and determine what size it is relative to the axis. Since speed is distance ÷ time you then use those values from the slope. So in this case

$$\text{Speed} = 4\text{m} \div 4\text{s} = 1\text{m/s}$$

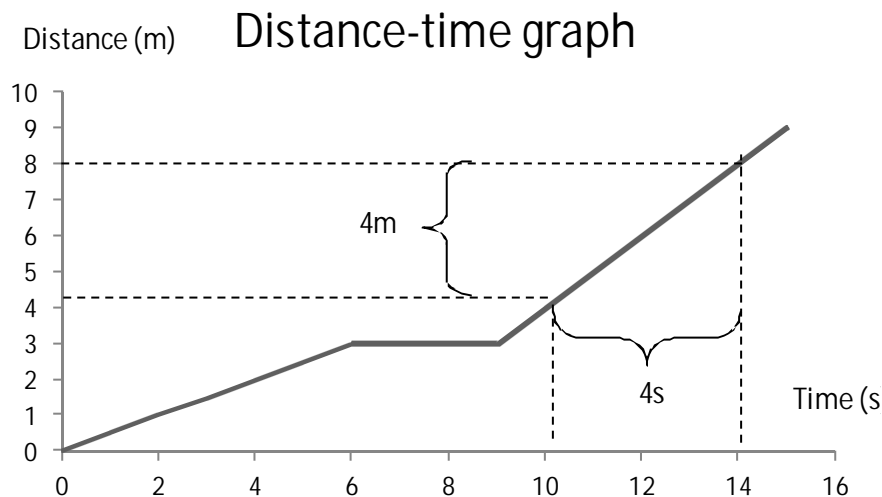

Speed is how fast you are travelling and velocity is your speed in a given direction.

Velocity-time graphs tell you how an objects velocity is changing over time. If there is a smooth slope on your graph then the object is accelerating. If there is a flat line then the object is moving at a constant speed. A steeper slope means a larger acceleration. If there is a downwards slope then the object is decelerating. The area under the velocity time graphs tells you the distance travelled.

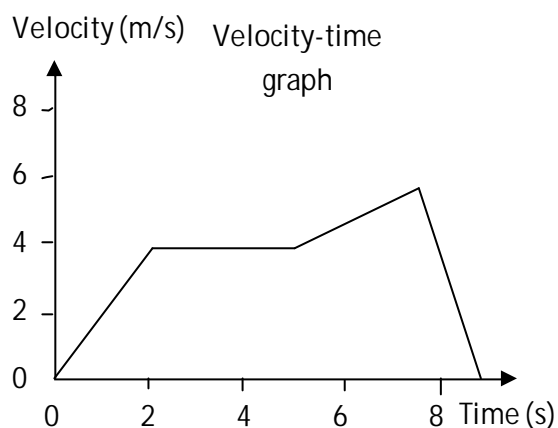

To work out the acceleration from a section of the slope you use the same method as above for the distance-time graph.

A velocity-time graph tells you how an objects velocity changes over a certain time. This is the acceleration.

$$\text{Acceleration (m/s}^2\text{)} = \frac{\text{Final velocity (m/s)} - \text{initial velocity (m/s)}}{\text{time taken (s)}}$$

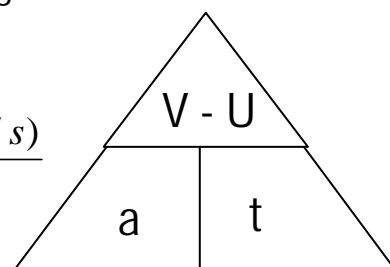

### Sample Question 3

A car is driven along a straight road. The graph shows how the velocity of the car changes during part of the journey.

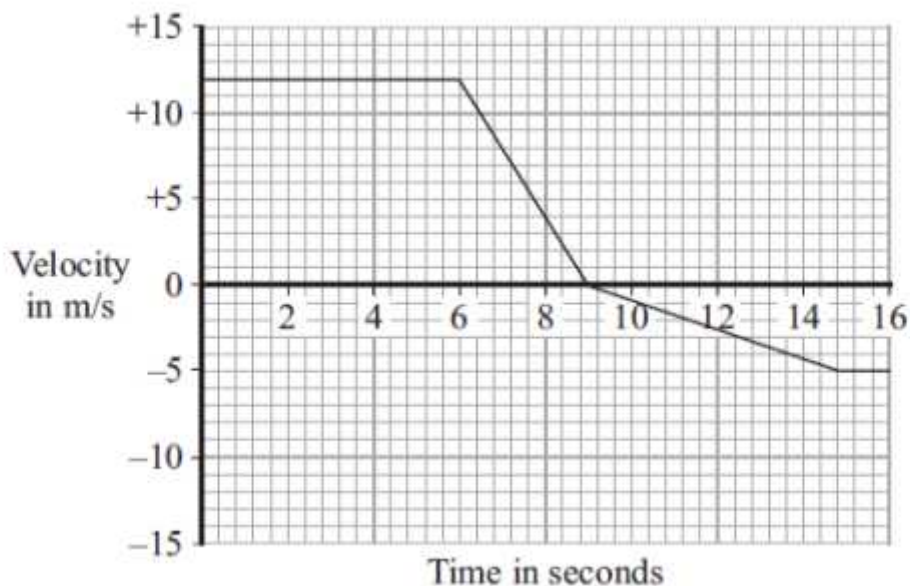

- (a) Use the graph to calculate the deceleration of the car between 6 and 9 seconds.

Show clearly how you work out your answer and give the unit.

.....

.....

.....

Deceleration = .....  
(3 marks)

- (b) At what time did the car change direction?

..... seconds  
(1 mark)

### Sample Question 4

The diagram shows the velocity-time graph for an object over a 10 second period.

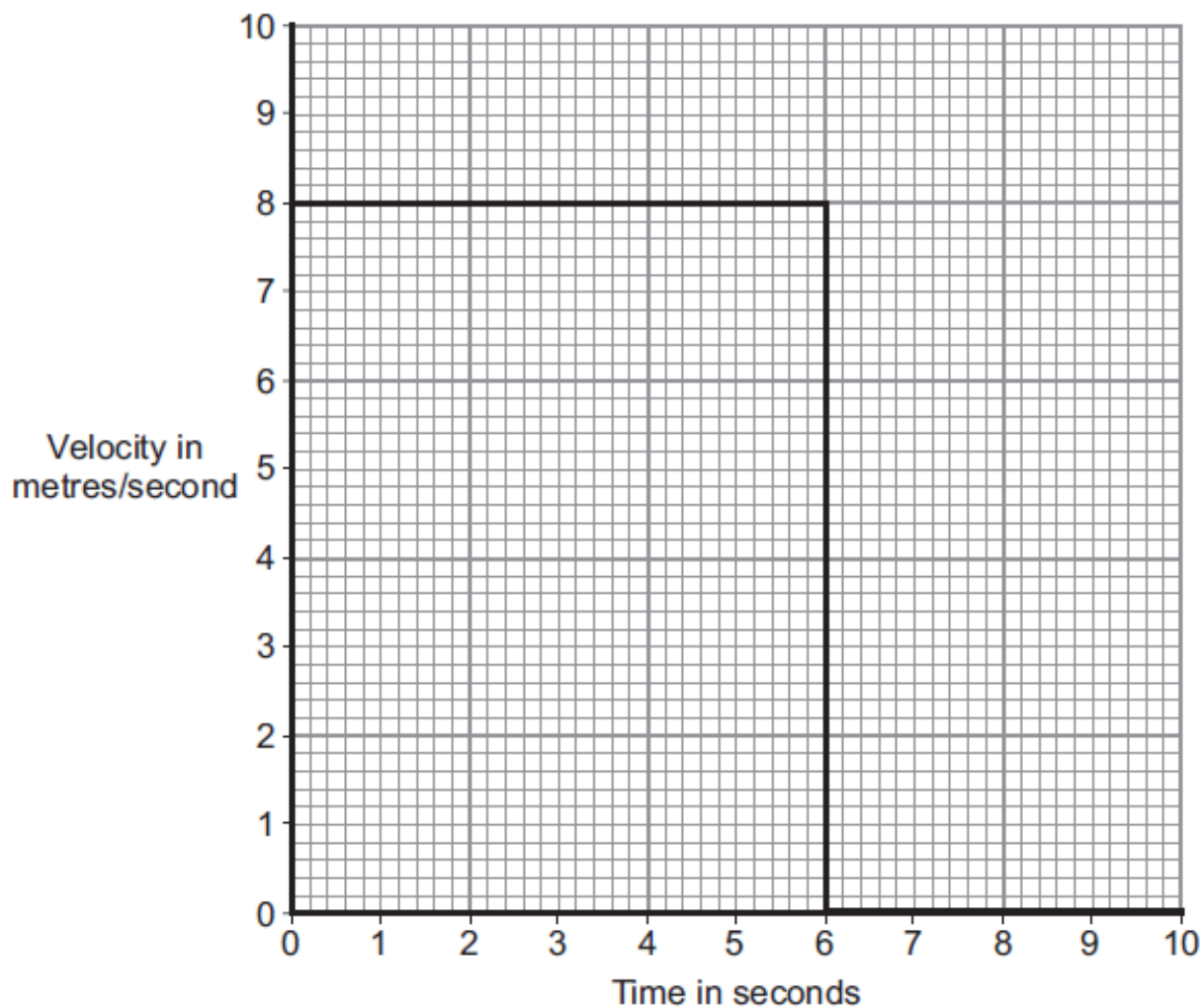

Use the graph to calculate the distance travelled by the object in 10 seconds.

Show clearly how you work out your answer.

.....  
.....

Distance = ..... m  
(2 marks)



(b) Complete the distance-time graph for the object over the same 10 seconds.

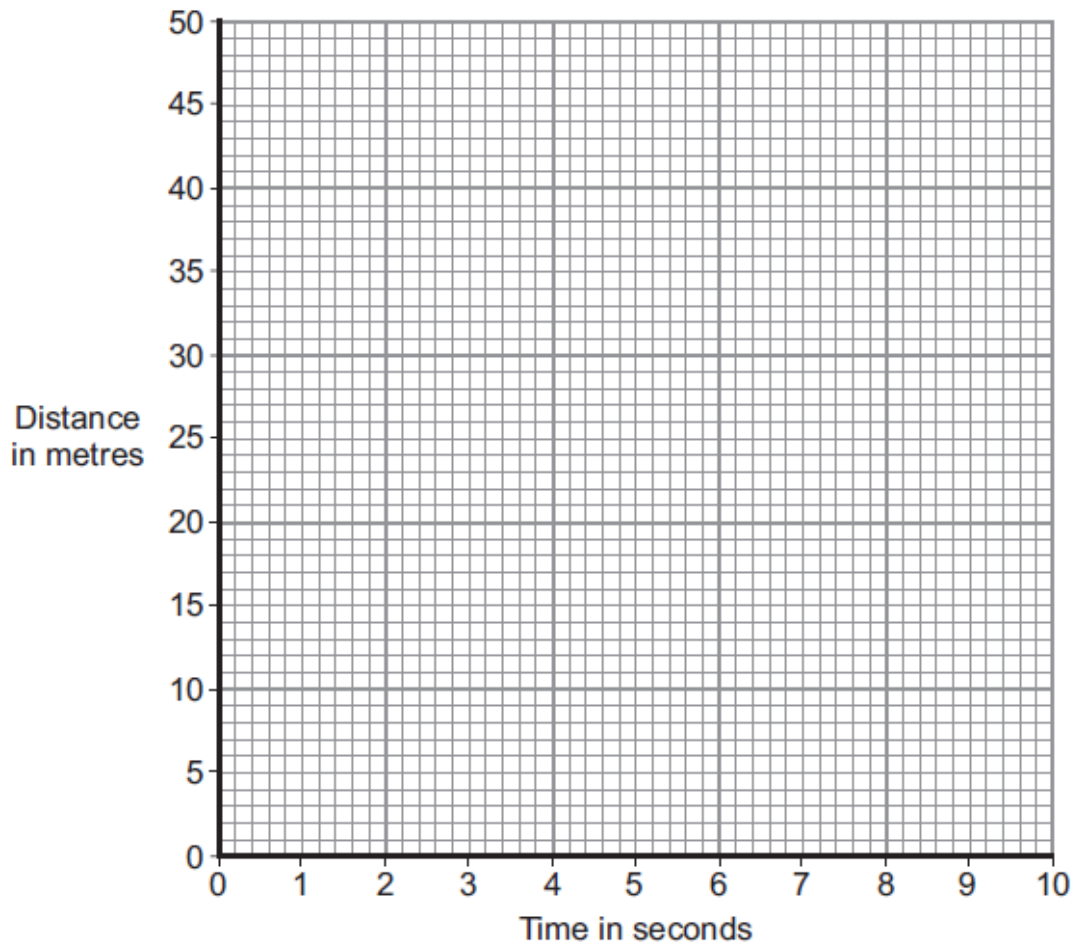

(2 marks)

### Cars and braking forces

How quickly a car can come to a stop depends on the car and the driver. The stopping distance is the thinking distance (which depends on the drivers reactions) and the braking distance (which depends on the car and road conditions).

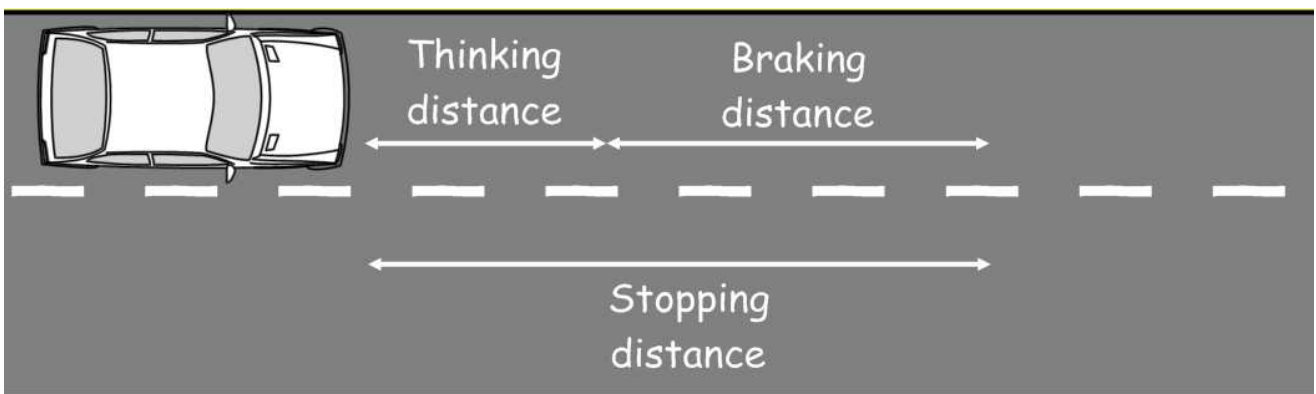

$$\text{Stopping distance} = \text{thinking distance} + \text{braking distance}$$

The thinking distance will be increased if the driver is tired, been drinking alcohol, been on drugs etc. The braking distance will depend on the road surface, weather conditions and how well the car responds e.g. condition of brakes.

Sample Question 5

The Highway Code gives tables of the shortest stopping distances for cars travelling at various speeds. An extract from the Highway Code is given below.

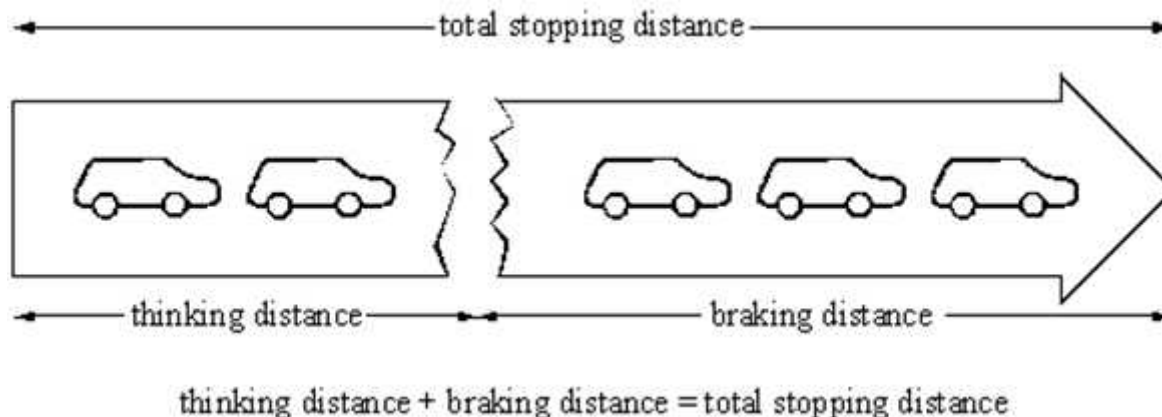

(a) A driver's reaction time is 0.7 s.

(i) Write down two factors which could increase a driver's reaction time.

- 1 .....
- 2 .....

(2)

(ii) What effect does an increase in reaction time have on:

- A thinking distance; .....
- B braking distance; .....
- C total stopping distance? .....

(3)

(b) Explain why the braking distance would change on a wet road.

.....

.....

.....

.....

.....

(2)

- (c) A car was travelling at 30 m/s. The driver braked. The graph below is a velocity-time graph showing the velocity of the car during braking.

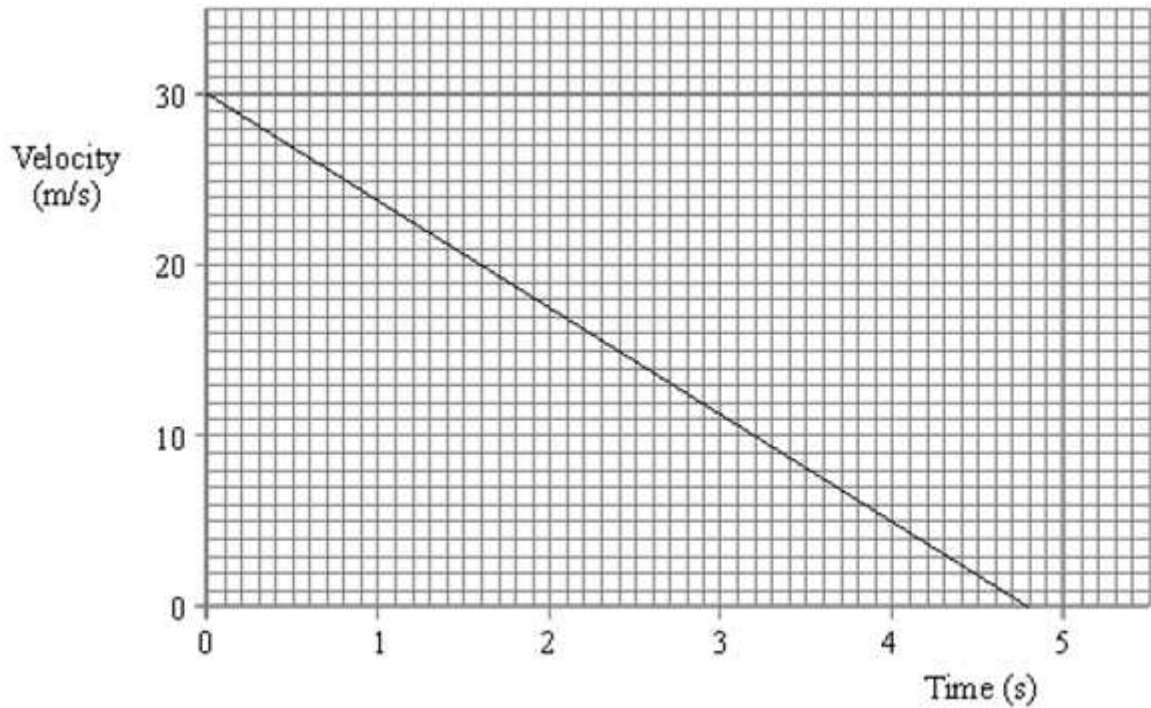

Calculate:

- (i) the rate at which the velocity decreases (deceleration);

.....  
 .....

Rate ..... m/s<sup>2</sup>

(2)

- (ii) the braking force, if the mass of the car is 900 kg;

.....  
 .....

Braking force ..... N

(2)

- (iii) the braking distance.

.....  
 .....

Braking distance ..... m

(2)

(Total 13 marks)

## Terminal velocity

An object falling through a fluid or gas will initially accelerate due to the force of gravity. Eventually the force of gravity will be balanced by the up thrust of the liquid/gas; this makes the resultant force zero and the object will move at its terminal velocity (steady speed).

The faster the object falls the greater the frictional force that acts.

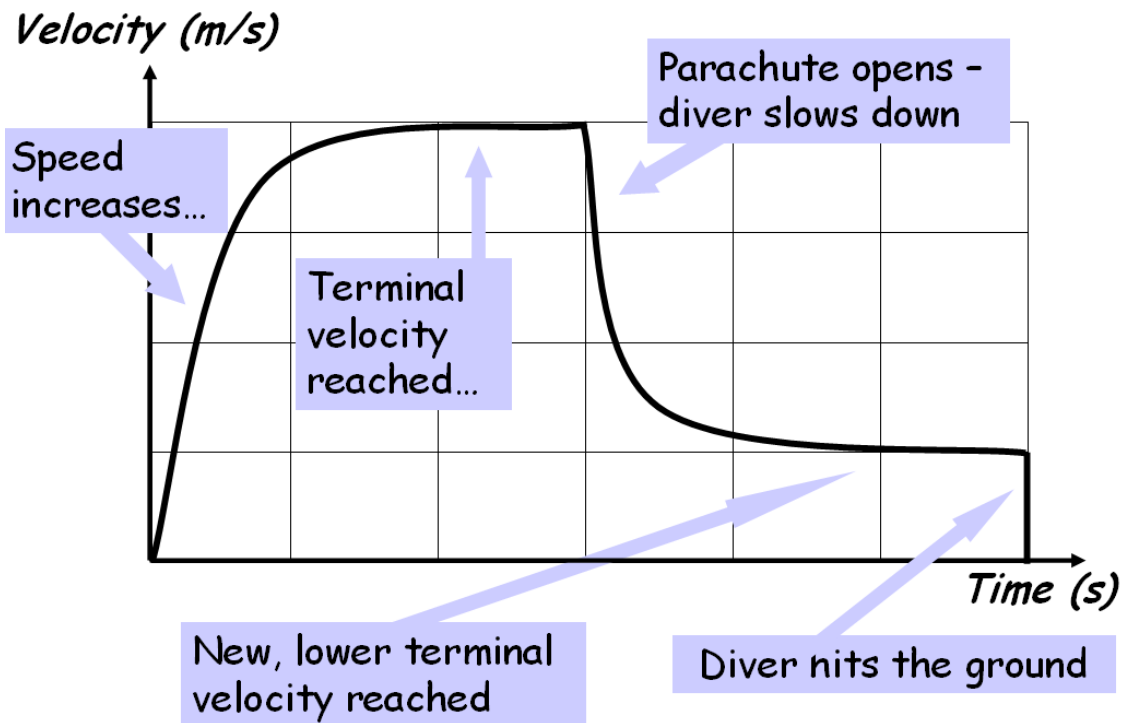

To the left is a velocity time graph for a sky diver who jumped out of a plane.

### Sample Question 6

- (a) The diagram shows a steel ball-bearing falling through a tube of oil. The forces, **L** and **M**, act on the ball-bearing.

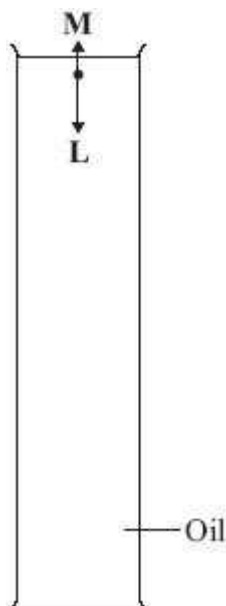

What causes force **L**?

.....

.....

.....

.....

(1)

- (b) The distance – time graph represents the motion of the ball-bearing as it falls through the oil.

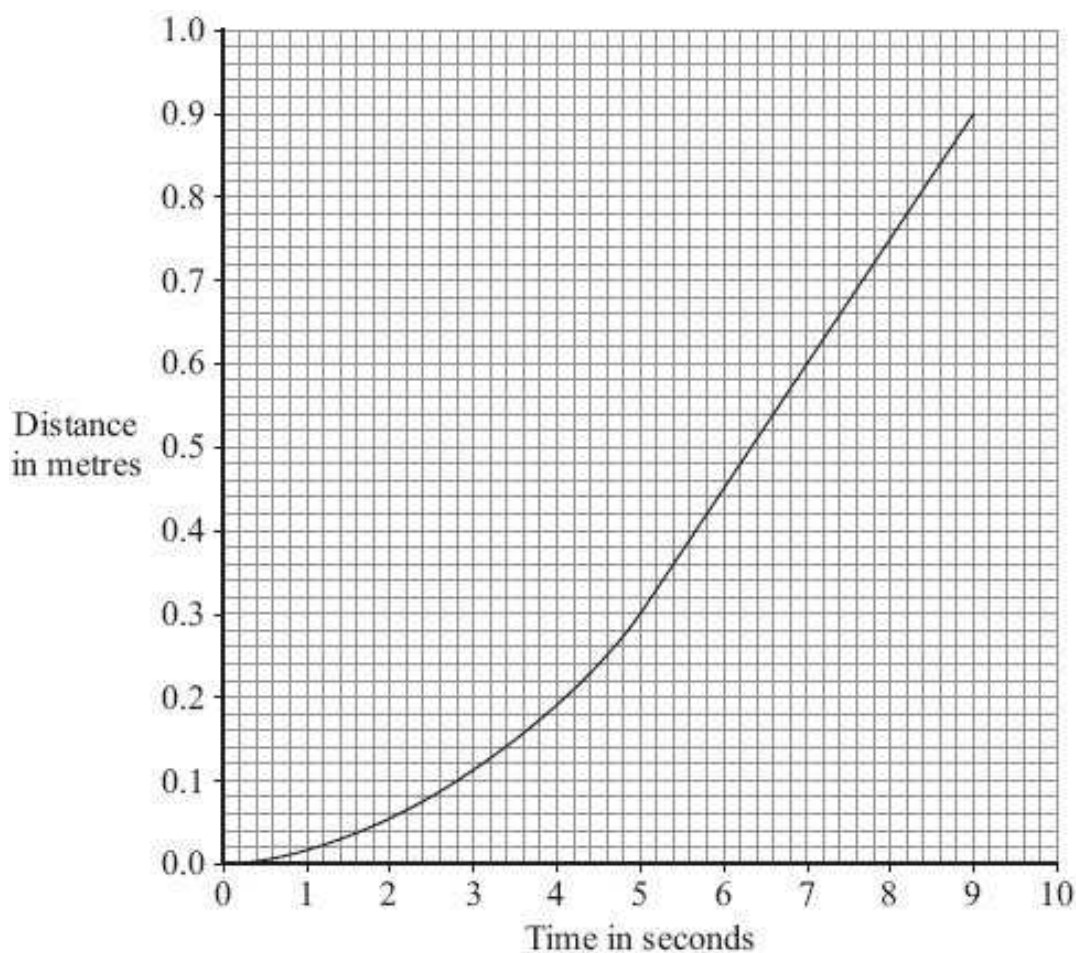

- (i) Explain, in terms of the forces, **L** and **M**, why the ball-bearing accelerates at first but then falls at constant speed.

.....

.....

.....

.....

.....

.....

(3)

- (ii) What name is given to the constant speed reached by the falling ball-bearing?

.....

(1)

(iii) Calculate the constant speed reached by the ball-bearing.

Show clearly how you use the graph to work out your answer.

.....  
.....  
.....

Speed = ..... m/s

(2)  
(Total 7 marks)

Hooke's Law

When a weight (force) is applied to a spring it extends. The amount it extends is proportional to the force added. It is governed by the equation:

Force (N) = spring constant (N/m) x extension (m)

$$(F = k \times e)$$

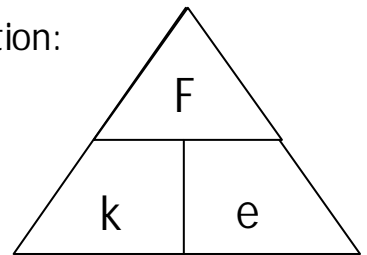

The spring constant can be determined from the gradient (slope of the line) on a force extension graph.

**Force extension graph for a spring**

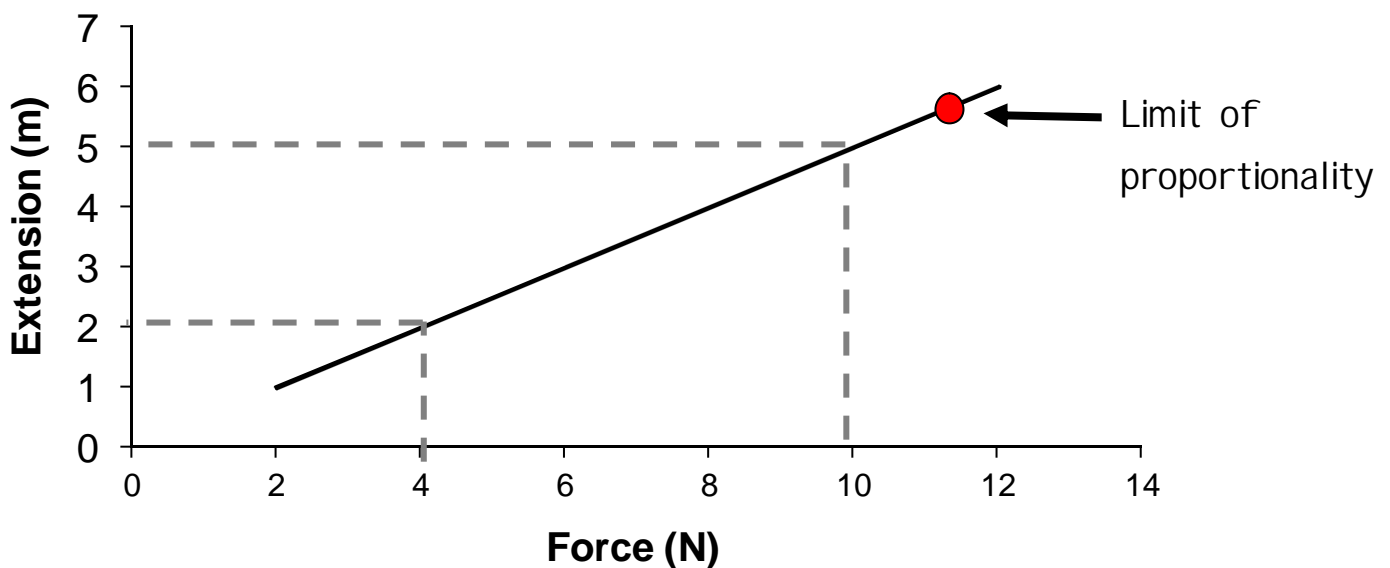

Choose a section of the line and measure the amount of force and the extension. Then divide the force by the extension

For example: In the sample graph the section of the line chosen is for a force of 6N and an extension of 3m.  $k = F \div e$   $k = 6 \div 3 = 2 \text{ N/m}$

Also marked on the graph is the limit of proportionality. This is the point at which the spring can still return to its original length. Beyond this point the spring can never go back to its original length/shape.

Sample Question 7

(a) The pictures show four objects. Each object has had its shape changed.



Bent metal ruler

**A**

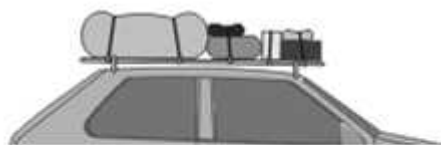

Stretched bungee cords

**B**



Springs on a playground ride

**C**



Moulded plastic model car body

**D**

Which of the objects are storing elastic potential energy?

.....

Explain the reason for your choice or choices.

.....

.....

.....

.....

.....

.....

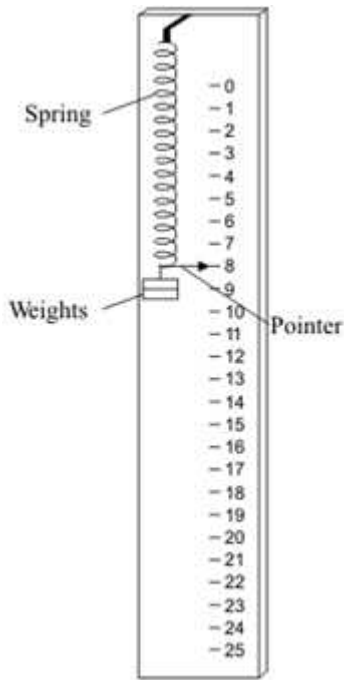

(b) A student makes a simple spring balance. To make a scale, the student uses a range of weights. Each weight is put onto the spring and the position of the pointer marked

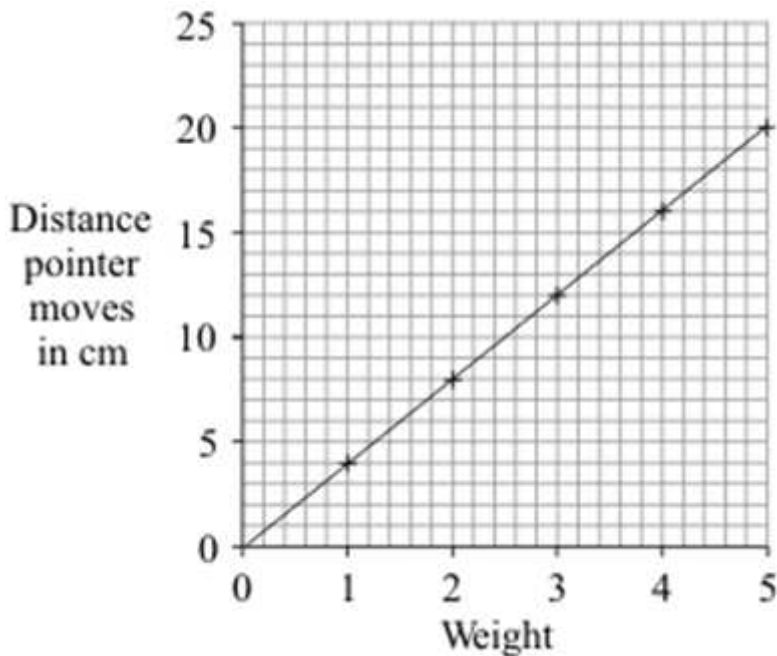

The graph below shows how increasing the weight made the pointer move further.

(i) Which **one** of the following is the unit of weight?.

Draw a ring around your answer.

- watt**
                         
  **joule**  
 **kilogram**
                         
  **newton**

(1)

(ii) What range of weights did the student use?

..... (1)

(iii) How far does the pointer move when 4 units of weight are on the spring?

..... (1)

(iv) The student ties a stone to the spring. The spring stretches 10 cm.

What is the weight of the stone?



## Force and energy

When a force acts upon an object causing it to move a through a distance energy is transferred and work is done. The amount of work done is equal to the amount of energy transferred. The amount of work done is calculated by:

Work done (Joules, J) = Force applied (N) x distance moved (m)

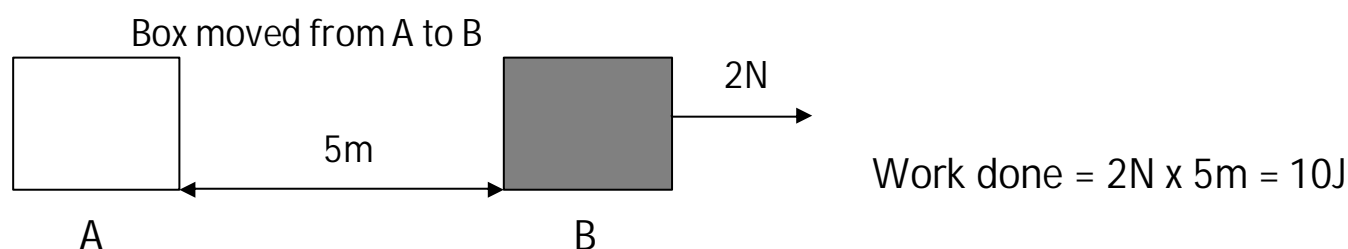

If you try to do work against a surface with friction then most of the energy gets transformed into heat.

Power is the amount of work done (energy transferred) every second and is calculated using the following equation

پاور = کام / وقت

$$P = \frac{W}{t}$$

Work can also be done on other objects. If you change the shape of an object then the energy gets stored in the object, e.g. an elastic band. This is elastic potential energy. Remember, potential energy is stored energy that is 'waiting' to be used, kinetic energy is movement energy.

Gravitational potential energy is the amount of energy an object has when it is held above the ground. It is calculated using the following equation

$$\text{Gravitational potential energy (J)} = \text{mass(kg)} \times \text{gravitational field (N/kg)} \times \text{height(m)}$$

Example: A book of mass 0.5kg is on a shelf 2 metres off the ground. What is its gravitational potential energy if the gravitational field strength is 10N/kg.

Answer: GPE = m x g x h

$$\text{GPE} = 0.5 \times 10 \times 2 = 10\text{J}$$

To work out the kinetic energy a body has you need to know its mass and its velocity;



Mass  
2000kg

Velocity  
60m/s

$$\begin{aligned} \text{Kinetic Energy} &= \frac{1}{2} \times 2000\text{kg} \times (50\text{m/s})^2 \\ &= \frac{1}{2} \times 2000\text{kg} \times 2500(\text{m/s})^2 \\ &= 2500000\text{J OR } 2500\text{kJ} \end{aligned}$$

## Momentum

Momentum (has the symbol p) describes how much motion an object has. It is measured in kilogram metre per second (kg m/s). Like velocity, momentum has magnitude acting in a certain direction.

$$\text{Momentum (kg m/s)} = \text{Mass (kg)} \times \text{Velocity (m/s)}$$

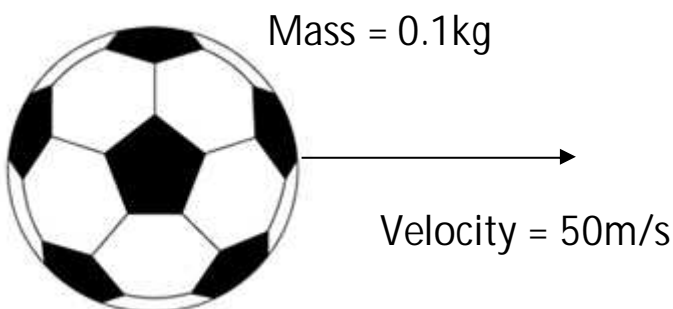

$$\begin{aligned} \text{Momentum} &= 0.1\text{kg} \times 50\text{m/s} \\ &= 5\text{kg m/s} \end{aligned}$$

In all situations, momentum is conserved, providing there are no external forces acting. For collisions, the momentum before the collision is equal to the momentum after the collision e.g. snooker balls

Momentum before collision      EQUALS      Momentum after collision

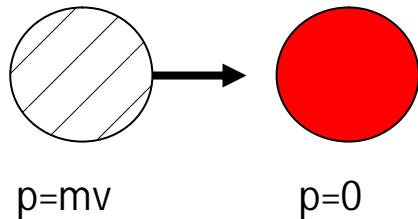

$$p = mv$$

$$p = 0$$

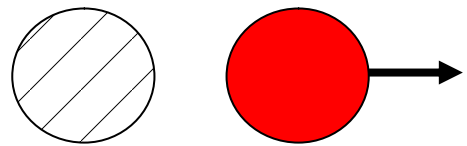

$$p = 0$$

$$p = mv$$

Another example is cannon before being fired and after being fired. Before the cannon is fired the momentum is zero, after it is fired the cannon ball moves forward and the cannon moves back. The momentum of the cannon ball is the same as the momentum of the cannon moving backwards.

In this sort of example you should choose one direction to be positive and the other direction to be negative. The example below illustrates this point. I will choose the right to be positive and the left to be negative.

Before being fired



$$p = 0$$

After being fired

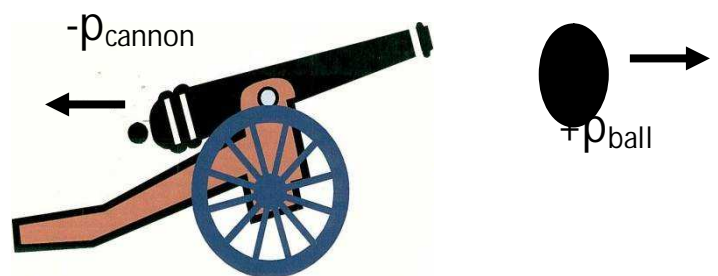

$$p_{\text{ball}} - p_{\text{cannon}} = 0$$

## Sample Question 8

The diagram shows a motorbike of mass 300 kg being ridden along a straight road.

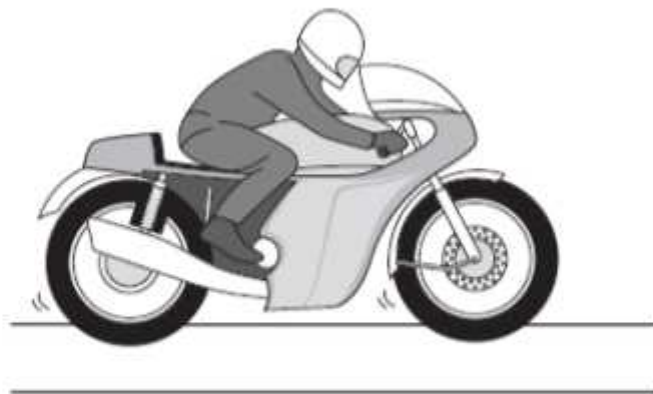

The rider sees a traffic queue ahead. He applies the brakes and reduces the speed of the motorbike from 18 m/s to 3 m/s.

- (a) Use the equation in the box to calculate the kinetic energy lost by the motorbike.

$$\text{kinetic energy} = \frac{1}{2} \times \text{mass} \times \text{speed}^2$$

Show clearly how you work out your answer.

.....

.....

.....

.....

Kinetic energy lost = ..... J  
(2 marks)

- (b) (i) How much work is done on the motorbike by the braking force?

.....  
(1 mark)

- (b) (ii) What happens to the kinetic energy lost by the motorbike?

.....  
(1 mark)

## Sample Question 9

The diagram shows a small, radio-controlled, flying toy. A fan inside the toy pushes air downwards creating the lift force on the toy.

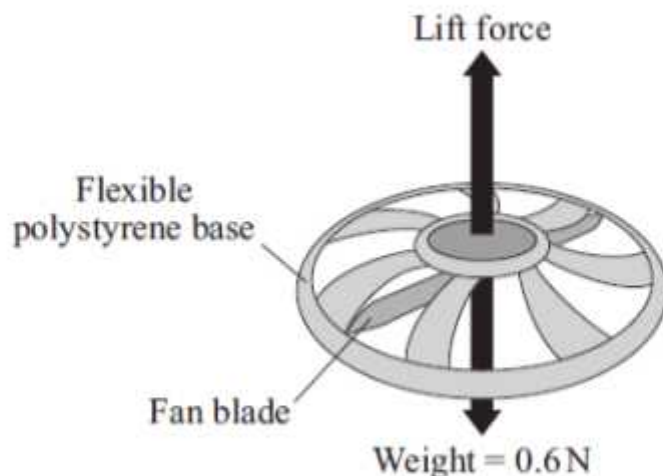

When the toy is hovering in mid-air, the fan is pushing 1.5 kg of air downwards every 10 seconds. Before the toy is switched on, the air is stationary.

- (a) Use the equations in the box to calculate the velocity of the air when the toy is hovering.

$\text{momentum} = \text{mass} \times \text{velocity}$ $\text{force} = \frac{\text{change in momentum}}{\text{time taken for the change}}$
--------------------------------------------------------------------------------------------------------------------------------------------

Show clearly how you work out your answer.

.....

.....

.....

Velocity = ..... m/s  
(3 marks)

(b) Explain why the toy accelerates upwards when the fan rotates faster.

.....

.....

.....

.....

(2 marks)

## Static electricity

In static electricity when two objects are rubbed together the electrons move from one object to another. This causes one object to have an overall positive charge and the other object to have an overall negative charge.

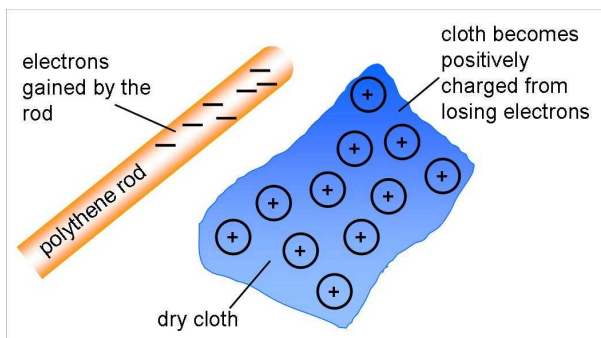

Like charges repel

Unlike charges attract

Neutral objects are attracted to both positively and negatively charged objects.

If you wanted to test if an object was charged then you could check if it attracted bits of paper, hair etc. It could attract or repel another charged object.

If an object becomes highly charged then the potential difference between then object and the ground increases and the objects will discharge. When a charged object discharges (goes to ground) then a spark might occur. This is the electrons jumping from the object to the earthed conductor.

## Sample Question 10

A pupil did an experiment following the instructions below.

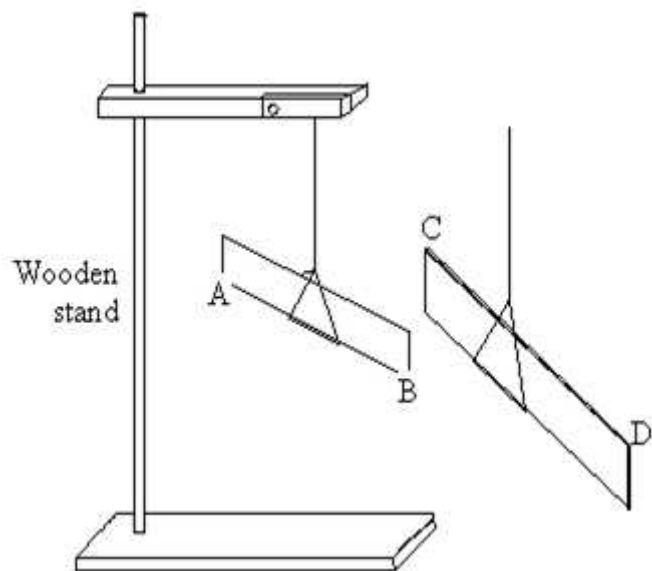

1. Take a polythene rod (AB), hold it at its centre and rub both ends with a cloth.

2. Suspend the rod, without touching the ends, from a stand using a stirrup and nylon thread.

3. Take a perspex rod (CD) and rub it with another cloth.

4. Without touching the ends of the perspex rod bring each end of the perspex rod up to, but without touching, each end of the polythene rod.

(a) When end C was brought near to end B they attracted each other.

(i) Explain why they attracted each other.

.....  
.....

(ii) What would happen if end C were brought near end A?

.....

(3)

(b) The experiment was repeated with two polythene rods.

(i) Describe what you would expect the pupil to observe as the end of one rod was brought near to the end of the other.

.....  
.....

(ii) Explain your answer.

.....  
.....

(2)

(c) Explain, in terms of electron movement, what happened as the rods were rubbed with the cloths.

.....

.....

.....







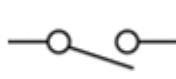
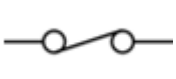
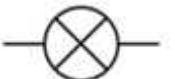
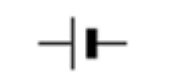

.....

.....

(3)  
(Total 8 marks)

## Current and circuits

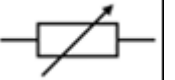
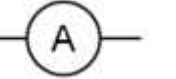
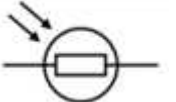
We use symbols in circuits and you need to be able to recognise and draw circuits using the following symbols.

 Open Switch	 Closed Switch	 Lamp	 Cell	 Diode	 Thermistor
 Battery	 Voltmeter (connect in parallel)	 Resistor	 Fuse	 Variable resistor	 Ammeter (connect in series)
 Light dependent resistor (LDR)			 Light emitting diode (LED)		

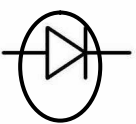
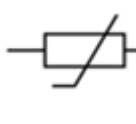
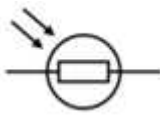
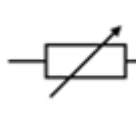
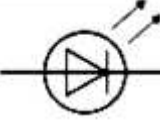
	A diode is a component that only allows current to flow one way in a circuit		This is a temperature resistor. As the temperature increases the resistance decreases
	A LDR is a resistor whose resistance decreases if the light intensity increases (more light shining on it)		This is a resistor whose resistance can be changed. E.g. a dimmer switch
	A light emitting diode (LED) is a component that only allows current to flow one way in a circuit and when the current is flowing that way it gives off light		



Current (symbol  $I$ , measured in amperes, A) is the rate of flow of electrical charges (symbol  $Q$ ) or electrons i.e. The number of charges per second.

Current is the amount of charges (measured in Coulombs) that flow every second, it is represented by the equation:

$$\text{Current (Ampere, A)} = \text{Charge (Coulombs, C)} \div \text{Time (s)}$$

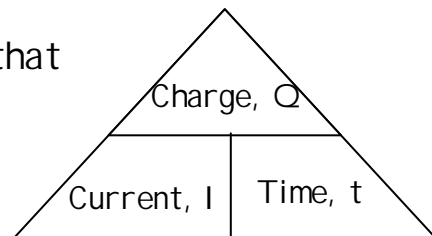

So if a circuit has a current of 2A that means that there are 2 coulombs of charge going around the circuit every second

Quick example: 6 Coulombs of charge go around a circuit every 2 seconds.  
What is the current?

Answer:  $I = Q \div t$                        $I = 6C \div 2s = 3A$

Voltage or potential difference (symbol  $V$ , measured in volts, v) is the amount of energy transferred by the charges i.e. the amount of energy per charge

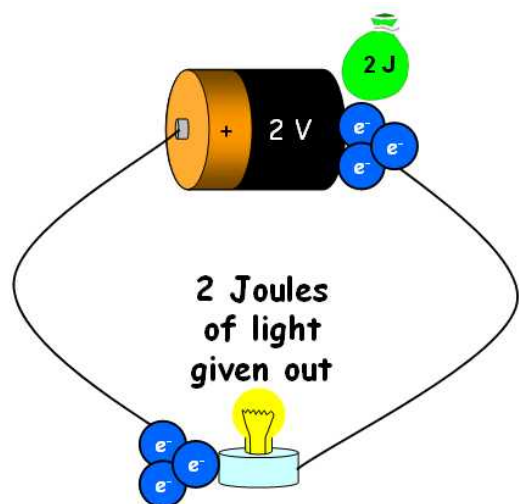

If there is a 2V cell or battery in a circuit then it gives 2 joules of energy to every coulomb of charge. When these charges get to the device in the circuit e.g. a bulb, then the energy gets transferred to the device. To calculate potential difference/voltage you use the following equation.

$$\text{Potential difference (V)} = \frac{\text{Work done (J)}}{\text{Charge (C)}}$$

Resistance (symbol  $R$ , measured in ohms,  $\Omega$ ) is something that opposes the flow of current.

Voltage, current and resistance related by the equation:  $V = I \times R$

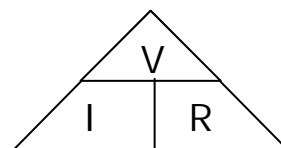

Current- potential difference graphs tell you how the current through a component varies with voltage.

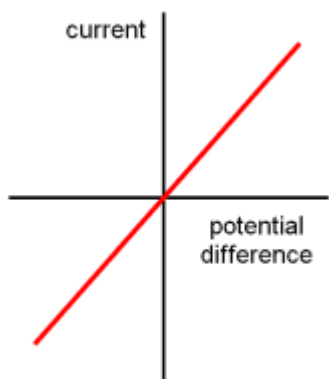

Resistor at a constant temperature

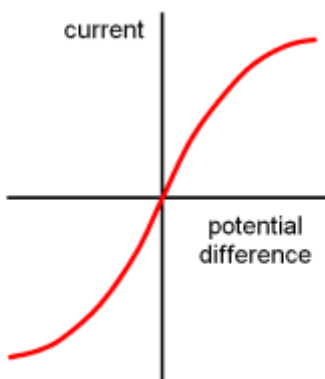

A filament lamp

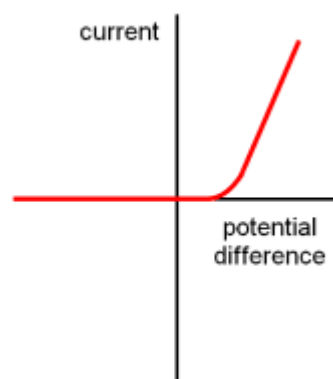

A diode

There are two types of circuits, parallel and series circuits.

In a series circuit

- The total resistance is the sum of the resistance of each component in the circuit
  - Total resistance ( $R_{\text{total}} = R_1 + R_2$ )
- The current is the same at every point in the circuit
- The voltage is shared between each component the circuit
  - Total voltage ( $V_{\text{total}} = V_1 + V_2$ )

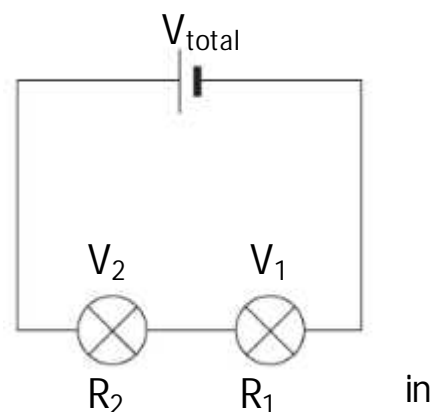

In a parallel circuit

- The voltage is the same across each branch
  - $V_{\text{total}} = V_1 = V_2$
- The total current through the circuit is the sum of the current through each component
  - Total current ( $I_{\text{total}} = I_1 + I_2$ )

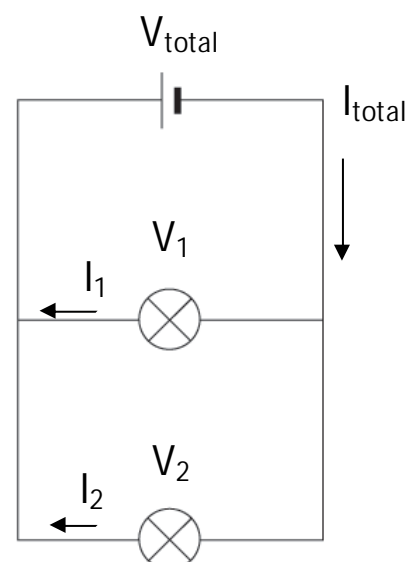

## Sample Question 11

- (a) The diagram shows the circuit used to investigate the resistance of a material. The diagram is incomplete: the ammeter and voltmeter are missing.

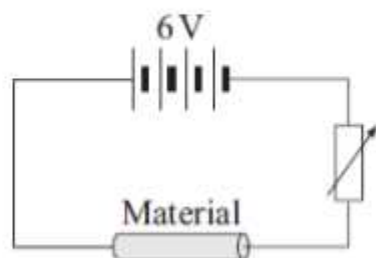

- (i) Draw the symbols for the ammeter and voltmeter on the diagram in the correct places. (2 marks)
- (ii) How can the current through the material be changed?

.....

.....

(1 mark)

## Sample Question 12

The diagram shows a simple type of car rear window heater. The six heating elements are exactly the same.

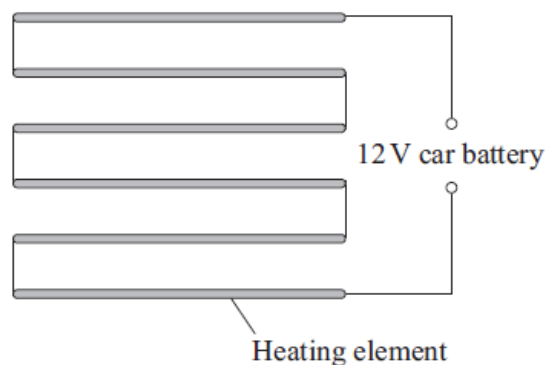

- (a) Each heating element has a resistance of  $5\ \Omega$ . The current passing through each element is  $0.4\ \text{A}$ .
- (a) (i) Calculate the total resistance of the six heating elements. Show clearly how you work out your answer.

.....

.....

Total resistance = ..... ohms  
(2 marks)

(a) (ii) Why is the current passing through each element the same?

.....

.....

(1 mark)

(a) (iii) What is the total current passing through the whole circuit?

.....

(1 mark)

(a) (iv) How is the 12 volt potential difference of the car battery shared between the six heating elements?

.....

.....

(1 mark)

### Sample Question 13

(a) The circuit diagram drawn below includes a component labelled X.

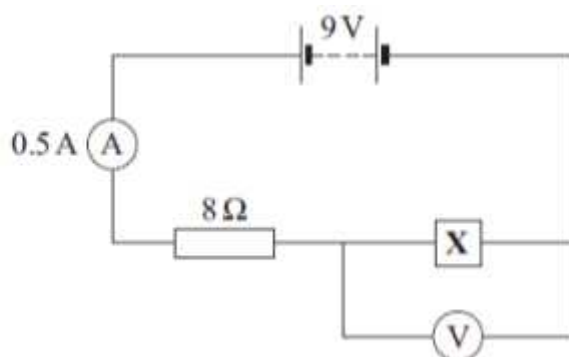

(a) (i) Use the equation in the box to calculate the potential difference across the 8 ohm resistor.

potential difference = current $\times$ resistance
----------------------------------------------------

Show clearly how you work out your answer.

.....

.....

Potential difference = ..... volts  
(2 marks)

(a) (ii) What is the potential difference across component X?

(1 mark)

## Mains electricity and safety

In circuits which are powered by cells/batteries the current only flows in one direction, this is called direct current (d.c.).

Alternating current (a.c.) is what we receive from power station and what comes out of plug sockets. This current changes direction i.e. the current move back and forth in the circuit. The properties of the UK electrical supply are 230 volts and the frequency is 50 cycles per second (50 Hertz [Hz]).

If you were to look at D.C and A.C current on an oscilloscope you can see how the voltage changes over time.

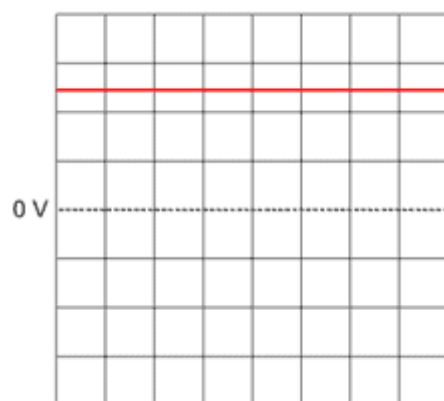

Direct current

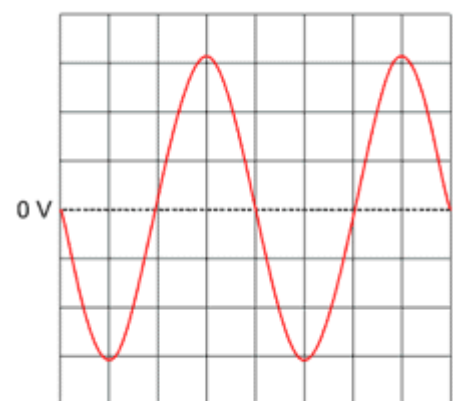

Alternating current

From the oscilloscope trace you can determine the period and frequency of the alternating current (A.C.)

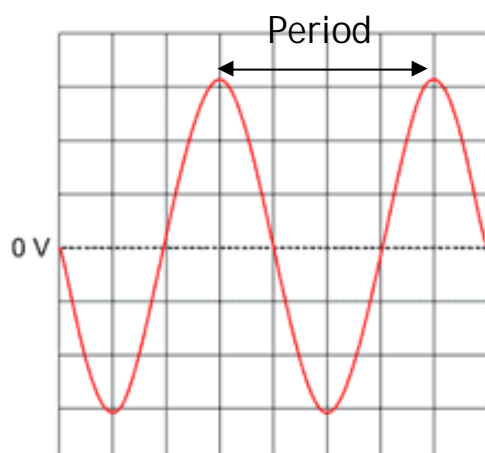

The period is the length of time for one complete wave to pass. In the oscilloscope trace on the left, there are 5 scale divisions for the period. If one scale division is 0.005 seconds then the period is 5 times that.

$$\text{Period} = 0.005\text{s} \times 5 = 0.02\text{seconds}$$

When you know the period you can calculate the frequency (the number of cycles per second)

$$f = \frac{1}{T}$$

0.02

Most of your electrical devices are connected to the mains supply by a cable connected to a three pin plug. The electrical cable is composed of a copper wire surrounded by a plastic insulator. The three pin plug consists of 3 separate wires called the Earth wire, Live wire and Neutral wire. The live and neutral wires are responsible for carrying the electrical supply to and from the mains supply.

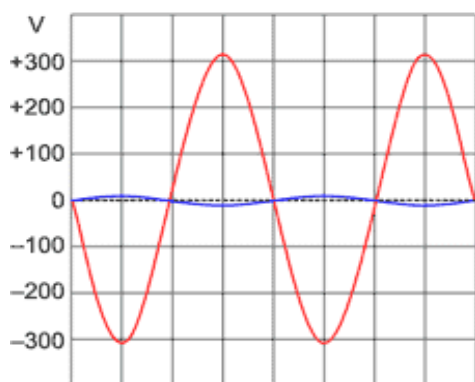
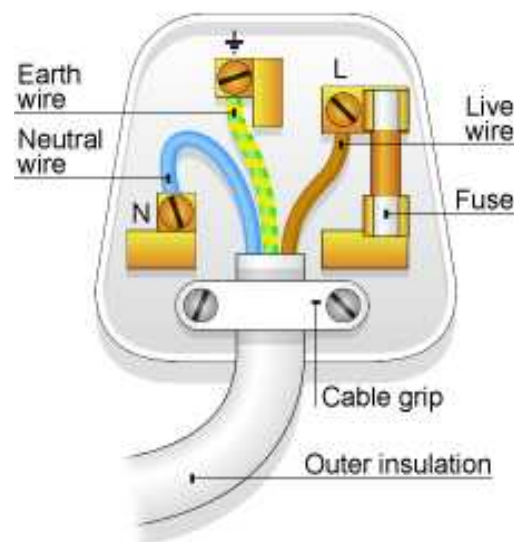

The voltage of the live wire (red line) alternates between positive and negative and the neutral wire (blue line) remains close to zero. The earth pin is used for safety (in particular with devices that have a metal case) in conjunction with the fuse. If the live wire happens to come in contact with the metal case then you could get an electrical shock as the current will pass through you to get to the ground. However, the earth wire and fuse prevents this from happening. The earth wire will take the current from the live wire. This high current then flows through the fuse wire causing it to melt.

### Fuses and circuit breakers

Fuses have different current ratings. The fuse will blow if the current exceeds this rating e.g. a 3 amp fuse will blow if the current is equal to or greater than 3 amps. Most common fuse ratings are 3A, 5A and 13A.

To know what rating of fuse to use you need to know the electrical power of the device. Electrical devices use different amounts of power (measured in watts). Power is the amount of energy transformed by the device every second. The way to calculate power other than the one mentioned earlier is:

$$\text{Power (W)} = \text{current (A)} \times \text{potential difference (V)}$$

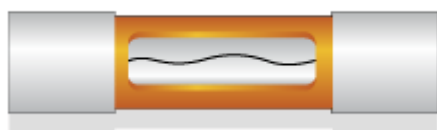
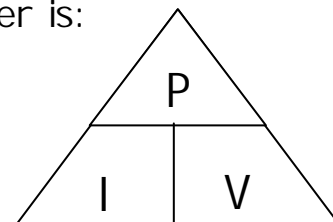

If an electrical fire has a power rating of 1150W and the voltage used is 230V then what fuse should be used?

Rearranging the equation we get:

$$I = P \div V$$

$$I = 1150 \div 230 = 5A$$

The fuse that should be used is 13A because if a 3A or 5A fuse was used then it would 'blow' even if the device was working correctly.

Another safety device is a circuit breaker which is an electromagnet switch which opens (or 'trips') when there is a fault which stops the current flowing. The electromagnet is connected in series with the live wire and if the current is too large this causes the magnetic field of the electromagnet to be big enough to pull the switch contacts apart. The switch will remain open until it is reset. These devices work quicker than fuses

There are also Residual Current Circuit Breaker (RCCB) which, like circuit breakers, but work much faster than circuit breakers and fuses.

### Sample Question 14

In the UK mains electricity is a 230 volt a.c. supply.

(a) What is the frequency of the a.c. mains electricity in the UK?

.....

(1)

(b) (i) What is an electric current?

.....

(1)

(ii) Explain the difference between an a.c. (alternating current) electricity supply and a d.c. (direct current) electricity supply.

.....  
.....  
.....  
.....

(2)

(c) A householder has a 10.8 kW electric shower installed in the bathroom.

(i) Calculate the current drawn from the mains electricity supply by the shower.

Write down the equation you use, and then show clearly how you work out your answer.

.....  
.....  
.....  
.....

Current = ..... A

(2)

(ii) The table gives the maximum current that can safely pass through electric cables of different cross-sectional area.

<b>Cross-sectional area in mm<sup>2</sup></b>	<b>Maximum safe current in amps</b>
1.0	11.5
2.5	20.0
4.0	27.0
6.0	34.0
10.0	46.0
16.0	62.0



The existing power sockets in the house are wired to the mains electricity supply using  $2.5 \text{ mm}^2$  cable.

Use the data in the table to explain why the shower must **not** be connected to the mains electricity supply using  $2.5 \text{ mm}^2$  cable.

.....  
.....  
.....  
.....

(2)

(iii) The circuit connecting the shower to the mains electricity supply must include a residual current circuit breaker (RCCB) and not a fuse.

Give **two** advantages of using a RCCB to protect a circuit rather than a fuse.

1 .....

.....

2 .....

.....

(2)

(Total 10 marks)

Sample Question 15

(a) Describe the difference between an alternating current (a.c.) and a direct current (d.c.).

.....  
.....  
.....  
.....

(2 marks)

(b) The diagram shows the information plate on the bottom of an electric wallpaper steamer.



(b) (i) Use the equation in the box to calculate the current used by the steamer.

$$\text{power} = \text{current} \times \text{potential difference}$$

Show clearly how you work out your answer.

.....

.....

Current ..... A  
(2 marks)

(b) (ii) Which **one** of the following fuses should be used inside the plug of the steamer?

Draw a ring around your answer.

- 1 A                      3 A                      5 A                      10 A                      13 A                      (1 mark)

### Sample Question 16

The diagram shows someone accidentally touching the live wire inside a dismantled 230 volt mains electricity socket.

A current flows through the person giving him an electric shock.



- (a) (i) Use the equation in the box to calculate the current that will flow through the person.

$\text{potential difference} = \text{current} \times \text{resistance}$
-------------------------------------------------------------------------

Show clearly how you work out your answer.

.....  
.....

Current = ..... A  
(2 marks)

- (a) (ii) Rubber is a good insulator.

Explain why it is a good idea for electricians to wear rubber soled boots when working.

.....  
.....  
.....  
.....

(2 marks)

- (b) If the current flowing through a person is too high, the person cannot let go of the electrical source.  
Different people were tested to see whether the ability to let go of an electrical source depended on the frequency of the current.

The results of the test are shown in the graph.

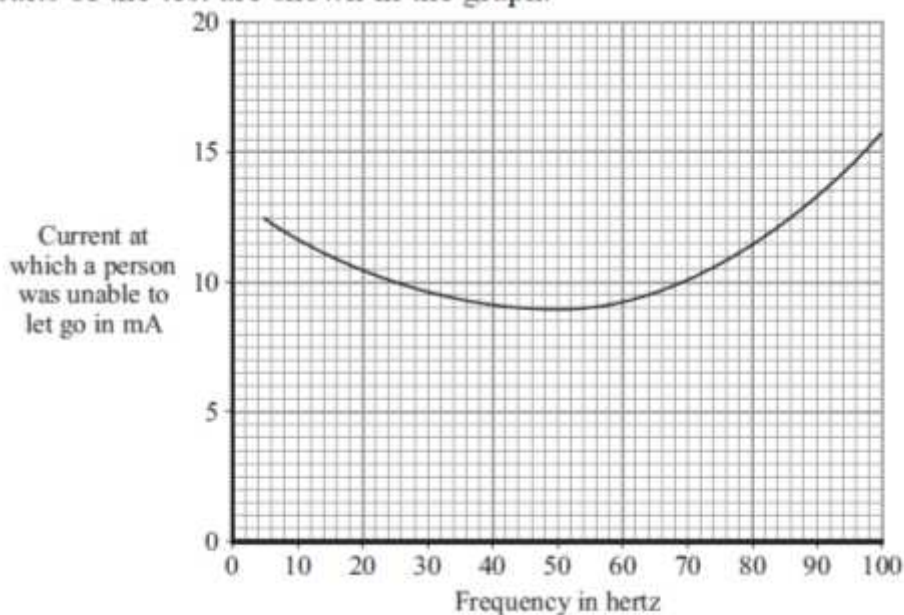

(b) (i) What is the frequency of the mains electricity supply in the UK?

.....  
(1 mark)

(b) (ii) From a safety point of view, is the frequency of the UK mains electricity supply suitable?

Give a reason for your answer.

.....  
.....  
(1 mark)

(c) The diagram shows how the electric supply cable is connected to an electric kettle. The earth wire is connected to the metal case of the kettle.

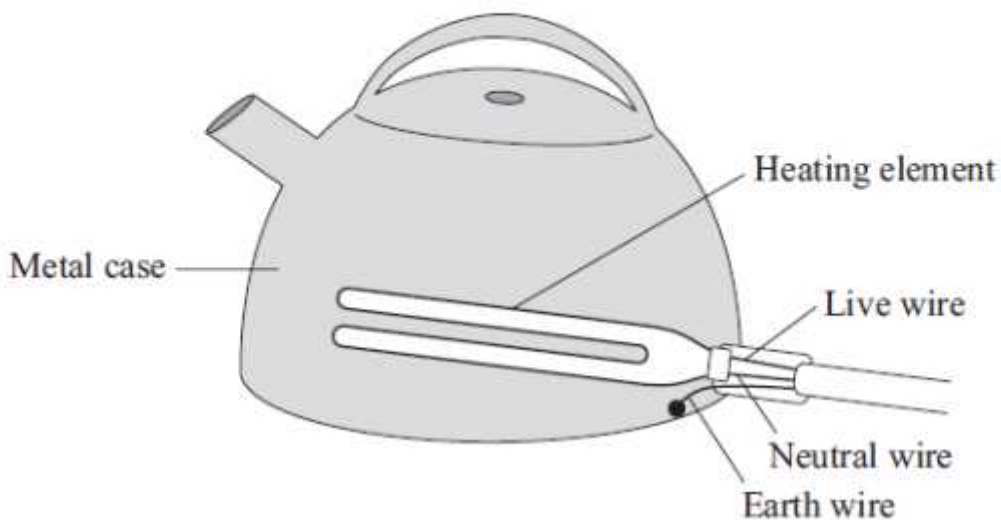

If a fault makes the metal case live, the earth wire and the fuse inside the plug protect anyone using the kettle from an electric shock.

Explain how.

.....  
.....  
.....  
.....  
(2 marks)

## Atoms and their properties

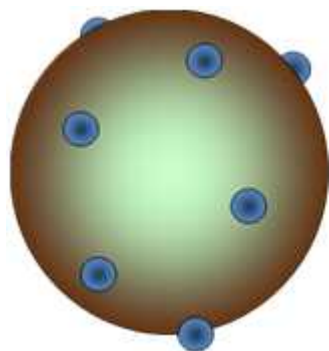

In the early 1900s the model of the atom was called the plum pudding model. It was believed that the atom was a positively charged fluid (the pudding) with electrons dotted inside it (the plums). This model was later disproved by Rutherford and Marsden's scattering experiment.

The way they disproved this was by firing alpha particles (positively charged particles) at a gold leaf and observing that angles at which they got reflected.

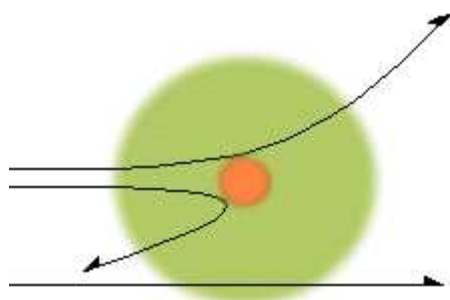

What they should have seen was the alpha particles passing practically straight through. However, what they discovered was that a number of the particles got deflected at different angles; with some coming straight back on themselves. What they concluded was that most of the atom was empty space with a small positively charged nucleus in the centre with electrons orbiting the outside.

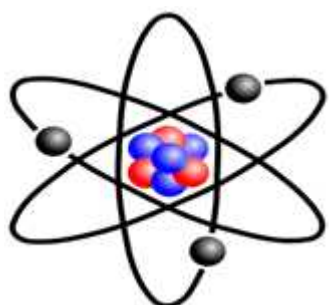

Atoms contain protons, neutrons and electrons. The nucleus is made up of protons and neutrons. All atoms of a particular element have the same number of protons e.g. all carbons have the same number of protons; one carbon atom won't have more protons than another. Atoms of different elements have different numbers of protons e.g. carbons atoms have a different number of protons to an oxygen atom.

The properties of the protons, neutrons and electrons are:

Particle	Relative mass	Relative charge
Proton	1	+1
Neutron	1	0 (no charge)
Electron	Very small (0.0005)	-1

Atoms normally have a no overall charge, due to have equal numbers of electrons and protons. However, atoms can gain or lose electrons and form charged particles called ions. Some forms of radiation can create ions and this radiation is called ionising radiation.

Atoms have a mass number which tells you the number of protons and neutrons in an atom. They also have an atomic number which tells you the number of protons in the atom.

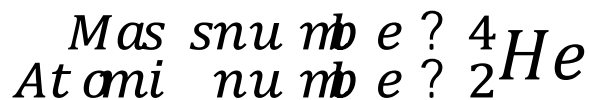

In electrically neutral atoms, the number of protons must equal the number of electrons.

Some atoms of the same element can have different mass numbers

For example: Carbon-12, Carbon-13, Carbon-14

In these atoms the number of protons hasn't changed, but the number of neutrons has e.g. carbon-14 has 2 more neutrons than carbon-12. These are called isotopes.

Isotopes which have an unstable nucleus (radio-isotopes) emit radiation or decay. There are 3 forms of radiation they can give out, beta particle, alpha particles and gamma rays.

Alpha decay ( ${}^4_2\alpha$ ) is where an alpha particle (a positively charged particle consisting of 2 neutrons and 2 protons i.e. a helium nucleus) is emitted from the nucleus of an atom. Alpha is the most ionising type of radiation.

Tip for remembering: Alpha has the letter p in it so it is positively charged. Alpha also has the letter h in it so it is a helium nucleus.

Beta decay ( ${}^0_{-1}\beta$ ) is when a beta particle (a fast moving electron) is emitted from the nucleus of an atom.

Tip for remembering: beta has the letter e in it so it is an electron.

Gamma decay (  $\gamma$  ) is where a gamma ray (part of the electromagnetic spectrum) is emitted from the atom. Gamma rays have no charge and no mass. Gamma is the least ionising form of radiation

Tip for remembering: Gamma has 2 m's beside each other which looks like a wave (mm -  $\sim$  ).

There are different sources that can give out radiation and radiation has been measured by geiger counters even when there was no known source of radiation around. This called background radiation and some sources are natural and others are man made.

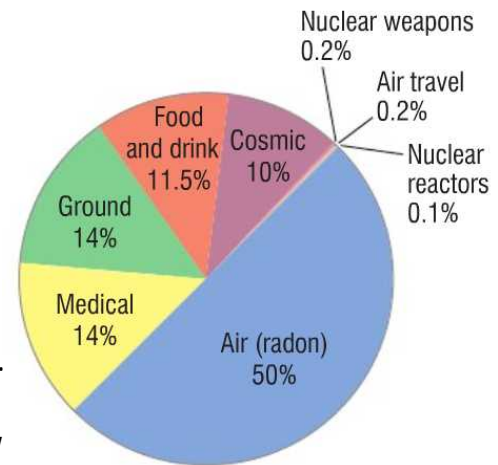

We can tell what radiation is emitted depending on how it gets deflected in a magnetic and electric field.

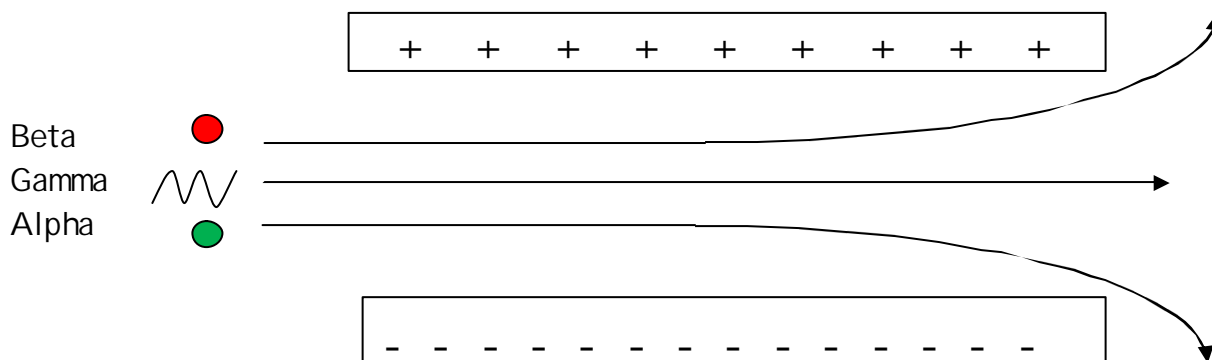

As a beta particle has a negative charge it will be repelled by the negatively charged plate and attracted to the positively charged plate. As a gamma ray is part of the electromagnetic spectrum and has no charge it will pass straight through. As an alpha particle has a positive charge it will be repelled by the positively charged plate and attracted to the negatively charged plate.

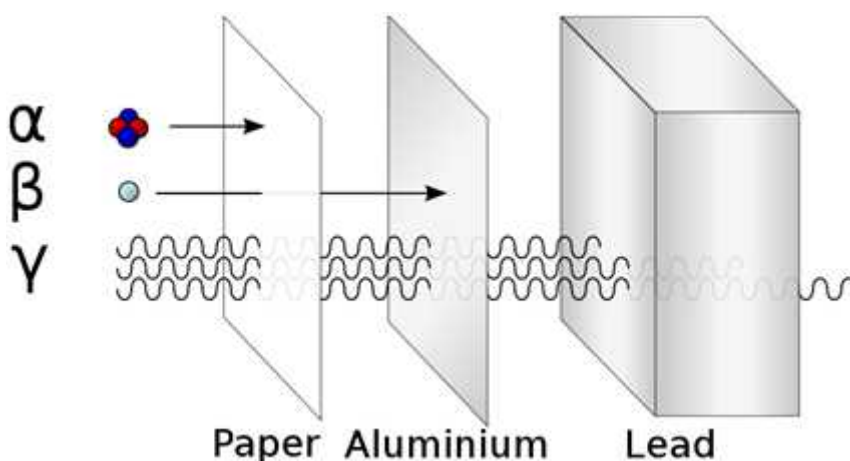

The different types of radiation emitted from isotopes can be stopped by different substances. It depends on how penetrating the radiation is. Alpha particles can be

stopped by your skin, paper or even a few centimetres of air. Beta is more penetrating and is stopped by a few centimetres of aluminium. Gamma is the most penetrating as is stopped by lead.

Alpha can be the most dangerous to humans as it is more likely to be absorbed by the cells. Beta and gamma are more likely to pass through your cells.

In order to measure how much radiation is given off by a substance we use a Geiger counter. A Geiger counter measures the count rate which is the amount of radiation emitted. The higher the count rate the more radiation is given off.

### An example of alpha and beta decay

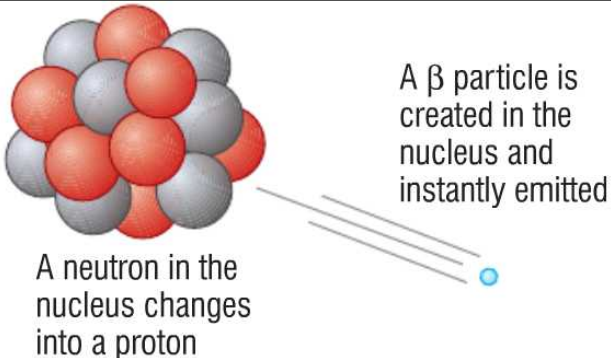

A  $\beta$  particle is created in the nucleus and instantly emitted

A neutron in the nucleus changes into a proton

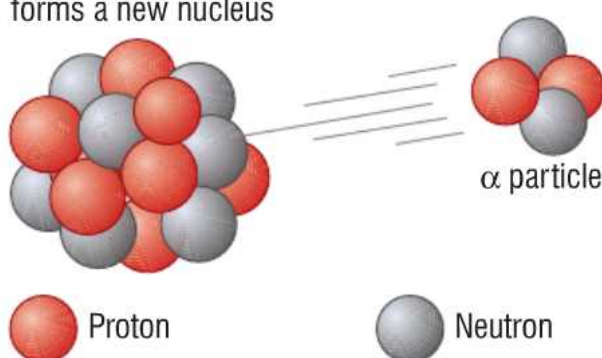
$${}_{19}^{40}\text{K} \longrightarrow {}_{20}^{40}\text{Ca} + {}_{-1}^0\beta$$

The nucleus emits an  $\alpha$  particle and forms a new nucleus

$\alpha$  particle

Proton Neutron

$${}_{90}^{228}\text{Th} \longrightarrow {}_{88}^{224}\text{Ra} + {}_2^4\alpha$$

Radioactive decay is a random process but there is a pattern to it. This

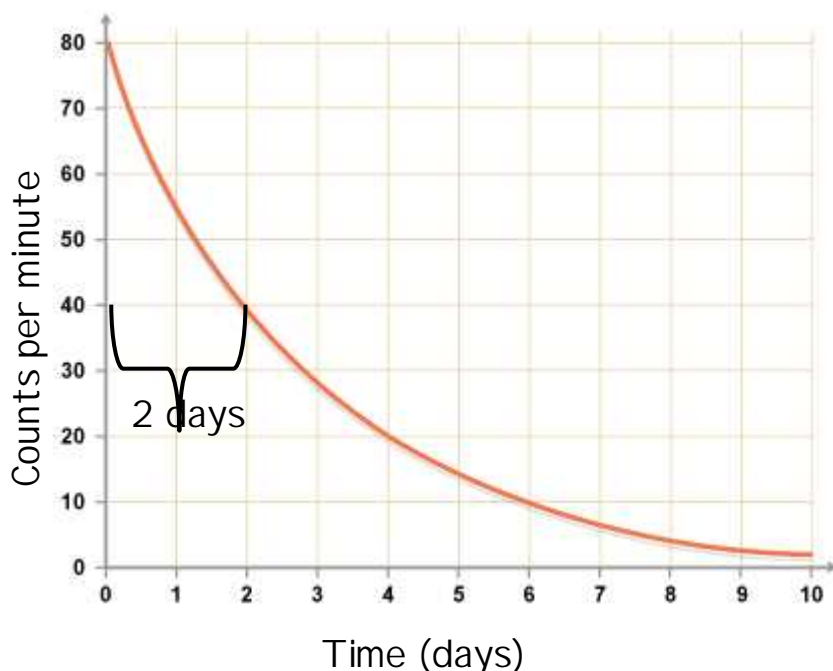

pattern is called the half-life. Half-life is the amount of time it takes for the radiation count rate to fall by half. So for the graph to the left the count rate starts at 80. The count rate will be half when it reaches 40. The time taken for it to reach 40 is 2 days. Therefore 2 days is the half life. After another 2



days the radiation will fall by half again and reached 20 counts per minute.

If we have a substance which has a mass of 50g and a half life of 2 days how would the mass of the substance change?

After 2 days the mass would be 25g (half of 50g). 25 g has radiated away.

After 4 days the mass would be 12.5g (half of 25g). 37.5g has radiated away.

After 6 days the mass would be 6.25g (half of 12.5g). 43.75g has radiated away and so on

### Uses of radioactive decay

People who work with radioactive source often wear special badges. These badges have a special photographic film in them which turns darker the bigger the exposure. Radioactive sources can be used as tracers. They can be added to plant fertiliser and you can then check if the plant has taken up the fertiliser. It is also used in the medical industry but doctors must ensure that it has a short half life so that it doesn't stay in the

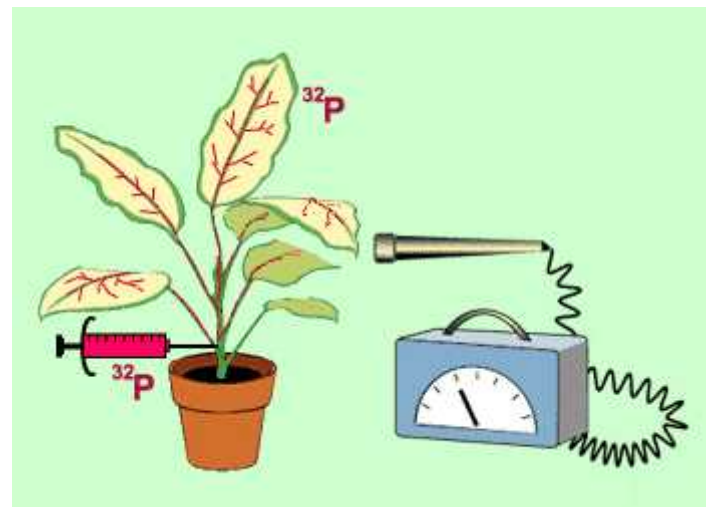

body very long and cause damage.

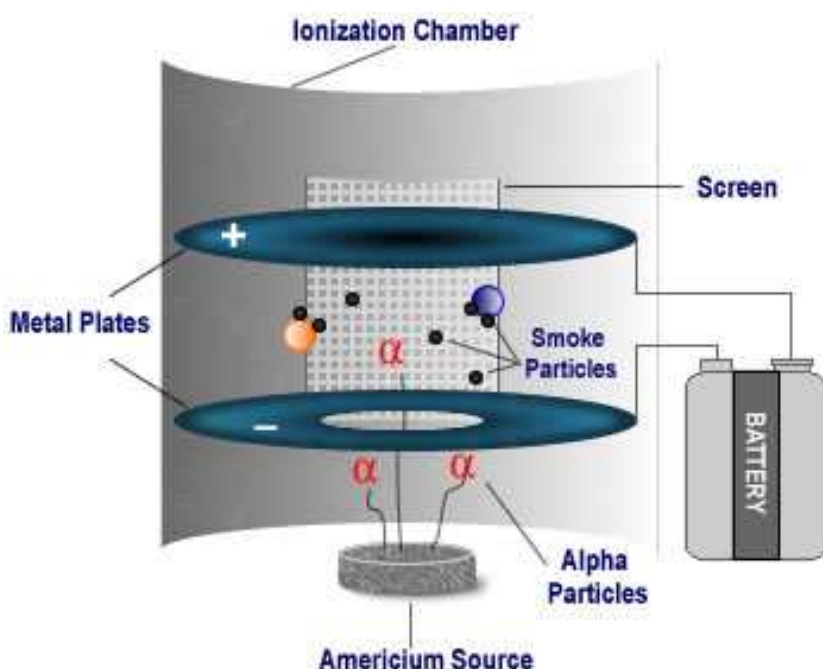

Alpha sources are used in smoke detectors. The alpha particles help to create an electric current in the smoke detector by ionising the air. When smoke particles enter the smoke detector the electric current drops, this causes the alarm to go off.

Beta particles are often used to measure the thickness of materials. A Geiger counter measures the amount of radiation passing through the material. If the radiation is too high then the sheet is too thin. If the radiation is too low then the material is too thick.

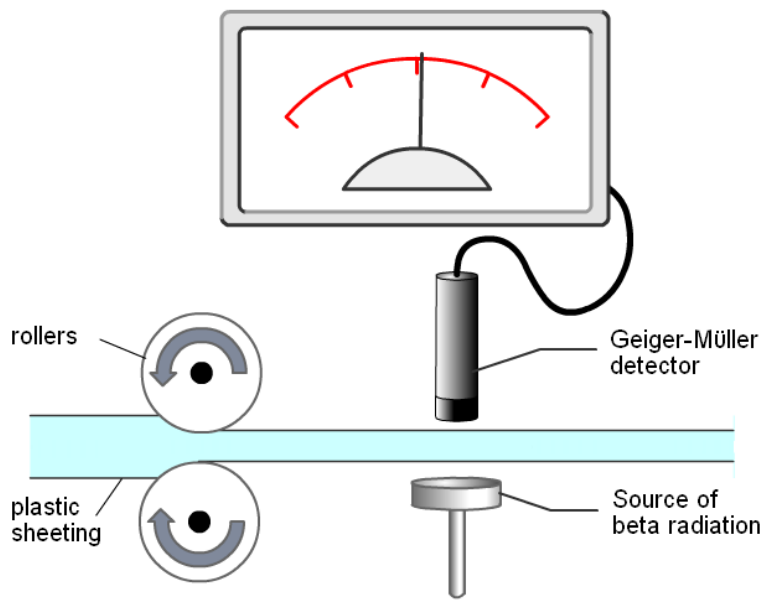

## Nuclear fission and fusion

Fusion is the easiest to remember as it is exactly like it sounds. Fusion is where two atomic nuclei join together to form a larger one. When this occurs energy is released. It is by this process that stars get their energy. For example, two hydrogen atoms can fuse together (and release energy) to create helium.

Fission is the opposite; it is the splitting of an atomic nucleus and it is the process that nuclear power plants use. The two most common fissionable materials are uranium 235 and plutonium 239.

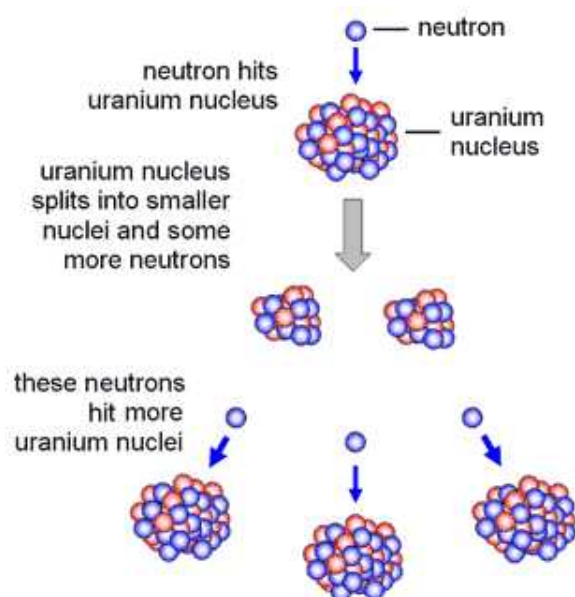

In order for fission to occur the atomic nucleus must absorb a neutron. The neutron is fired at the nucleus and caused the nucleus to split, forming two smaller nuclei. When the splitting occurs energy is released along with 2 or 3 more neutrons. These neutrons are then absorbed by other nuclei causing the process to repeat. This is called a chain reaction. This reaction is controlled in a nuclear reactor by using control rods. These rods absorb neutrons if

the reaction needs to be slowed down.

## Sample question 17

In 1986, a nuclear reactor exploded in a power station at Chernobyl in the Ukraine.

- (a) The table gives information about some of the radioactive substances released into the air by the explosion.

<b>Radioactive substance</b>	<b>Half-life</b>	<b>Type of radiation emitted</b>
Iodine-131	8 days	beta and gamma
Caesium-134	2 years	beta
Caesium-137	30 years	beta

- (a) (i) How is the structure of a caesium-134 atom different from the structure of a caesium-137 atom?

.....  
(1 mark)

- (a) (ii) What is a beta particle and from which part of an atom is a beta particle emitted?

.....  
.....  
(1 mark)

- (a) (iii) Once a radioactive substance is dissolved in rainwater, it can enter the food chain.

Following the Chernobyl explosion, some milk supplies were found to be radioactive.

If one litre of milk contaminated with iodine-131 gives a count rate of 400 counts/second, how long will it take for the count rate to fall to 25 counts/second?

Show clearly how you work out your answer.

.....  
.....  
.....

Time taken = ..... days  
(2 marks)

- (a) (iv) After 20 years, the caesium-137 emitted into the atmosphere is a more serious problem than the iodine-131.

Explain why.

.....  
.....  
.....  
.....  
.....

(2 marks)

### Sample question 18

Most elements have some *isotopes* which are *radioactive*.

- (a) What is meant by the terms:

- (a) (i) *isotopes*

.....  
.....

(1 mark)

(a) (ii) *radioactive?*

.....  
.....

(1 mark)

(b) The graph shows how the number of nuclei in a sample of the radioactive isotope plutonium-238 changes with time.

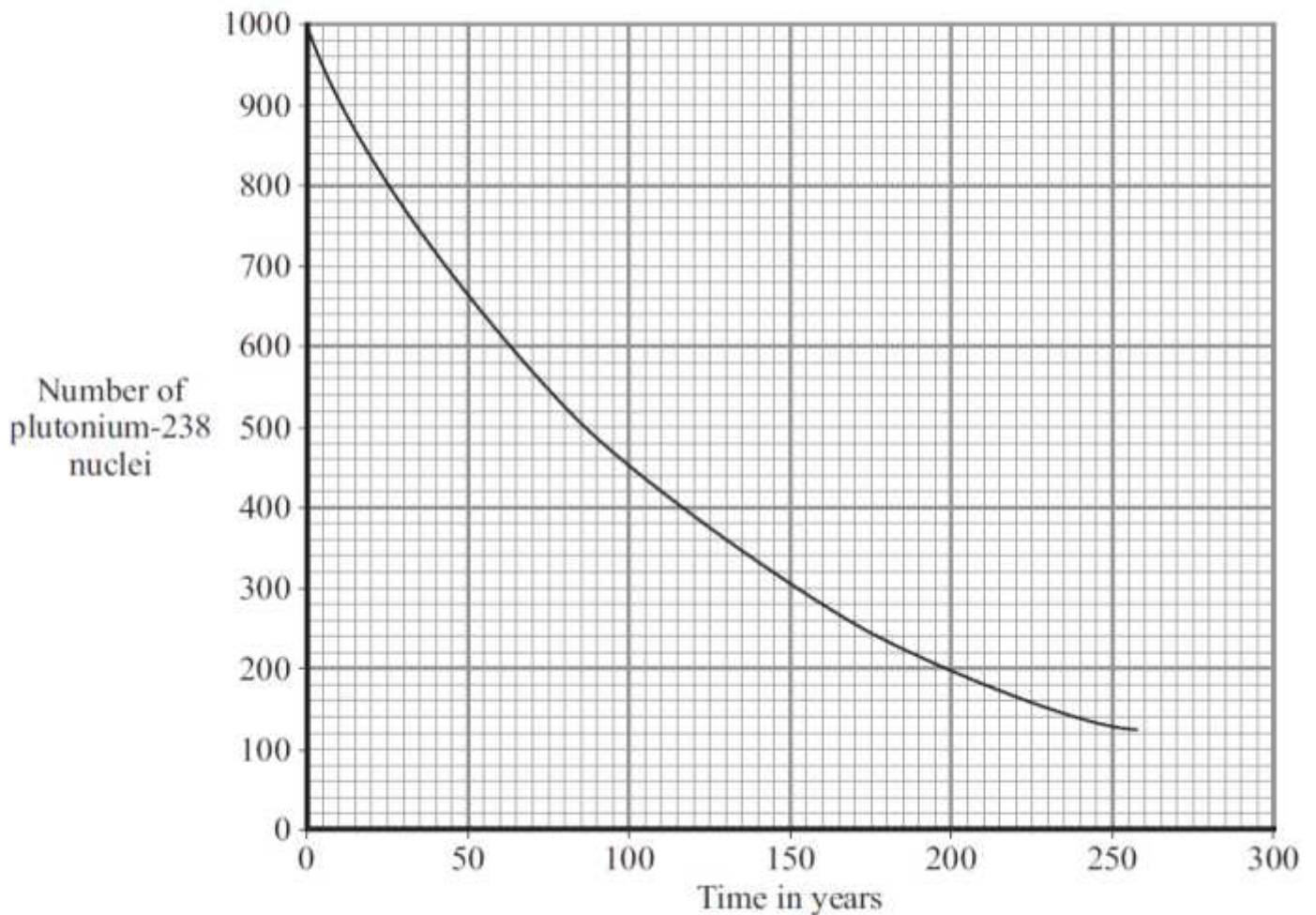

Use the graph to find the half-life of plutonium-238.

Show clearly on the graph how you obtain your answer.

Half-life = ..... years  
(2 marks)

(c) The Cassini spacecraft launched in 1997 took seven years to reach Saturn. The electricity to power the instruments on board the spacecraft is generated using the heat produced from the decay of plutonium-238.

- (c) (i) Plutonium-238 decays by emitting alpha particles.

What is an alpha particle?

.....  
(1 mark)

- (c) (ii) During the 11 years that Cassini will orbit Saturn, the output from the generators will decrease.

Explain why.

.....  
.....  
.....  
.....  
(2 marks)

- (d) Plutonium-238 is highly dangerous. A tiny amount taken into the body is enough to kill a human.

- (d) (i) Plutonium-238 is unlikely to cause any harm if it is outside the body but is likely to kill if it is inside the body.

Explain why.

.....  
.....  
.....  
.....  
(2 marks)

- (d) (ii) In 1964, a satellite powered by plutonium-238 was destroyed, causing the release of radioactive material into the atmosphere.

Suggest why some environmental groups protested about the launch of Cassini.

.....  
.....  
(1 mark)

## Sample Question 19

The table gives information about the three types of particle that make up an atom.

Particle	Relative mass	Relative charge
Proton		+1
Neutron	1	
Electron	very small	-1

(a) Complete the table by adding the two missing values. (2 marks)

(b) Use the information in the table to explain why an atom has no overall electrical charge.

.....

.....

.....

.....

(2 marks)

(c) Uranium has two natural isotopes, uranium-235 and uranium-238.  
Uranium-235 is used as a fuel inside a nuclear reactor.  
Inside the reactor, atoms of uranium-235 are split and energy is released.

(c) (i) How is the structure of an atom of uranium-235 different from the structure of an atom of uranium-238?

.....

.....

(1 mark)

(c) (ii) The nucleus of a uranium-235 atom must absorb a particle before the atom is able to split.

What type of particle is absorbed?

.....

(1 mark)

- (c) (iii) The nucleus of an atom splits into smaller parts in a reactor.

What name is given to this process?

.....  
(1 mark)

### Sample Question 20

- (a) The diagram shows what can happen when the nucleus of a uranium atom absorbs a neutron.

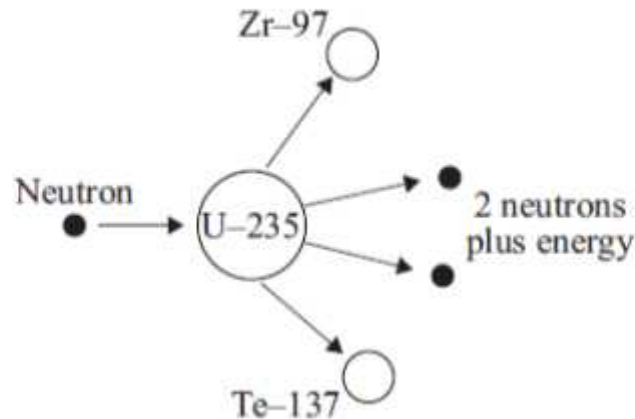

- (i) What name is given to the process shown in the diagram?

.....  
(1 mark)

- (ii) Explain how this process could lead to a chain reaction.

You may wish to add further detail to the diagram to help your answer.

.....  
.....  
.....  
.....  
(2 marks)

- (iii) How does the mass number of an atom change when its nucleus absorbs a neutron?

.....  
(1 mark)



## Life cycle of stars

Planets form when lumps of rock get attracted to each other due to gravity.

Stars form when clouds of gas and dust from space gets pulled together due to the gravitational attraction. The amount of gas build up (gets more concentrated and forms a protostar. When the protostar gets denser and hotter nuclear reactions (i.e. fusion) start which causes hydrogen and other lighter element to fuse together. During fusion energy gets released which is what makes stars hot.

Protostars then become main sequence stars when the forces within the star are balanced (gravitational force and expansion/outward force). Our sun is a main sequence star. After the main sequence star their life cycle can take 2 possible routes depending on their mass.

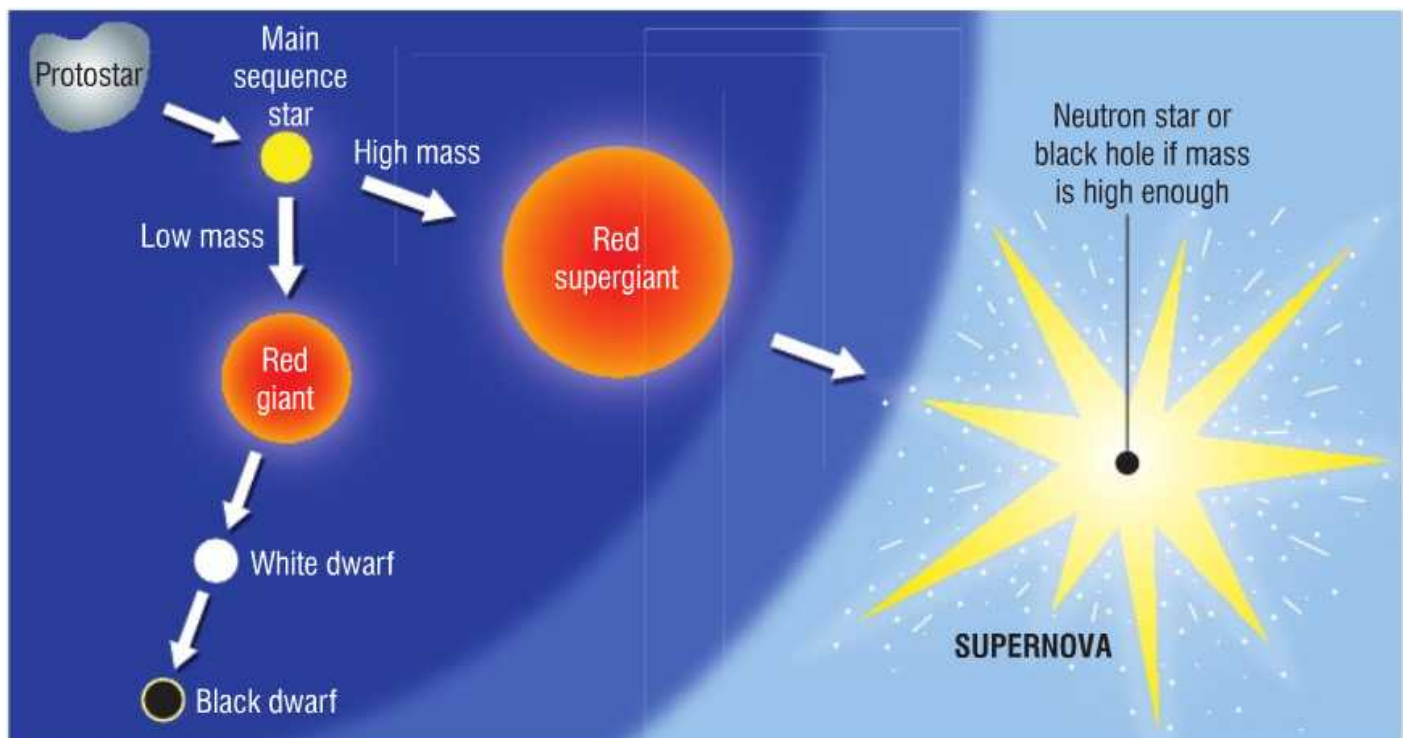

When the big bang occurred 13 billion years ago the only element in existence was hydrogen. However, due to nuclear fusion in stars all the other elements were created and when stars explode (go supernova) all of those elements are released into the universe. This means that the elements that make up your body, the oxygen that you breathe right now were formed inside stars.

## Sample Question 21

(a) Choose the best words from the box to complete the following sentences.

<b>billions</b>	<b>fission</b>	<b>friction</b>	<b>fusion</b>	<b>gases</b>
<b>gravity</b>	<b>liquids</b>	<b>millions</b>	<b>thousands</b>	

(i) Stars form when enough dust and ..... from space are pulled together by .....

(2)

(ii) Stars are able to give out energy for millions of years by the process of .....

(1)

(iii) The Sun is one of many ..... of stars in our galaxy. (1)

(b) What is the name of our galaxy?

(1)

(Total 5 marks)

## Sample Question 22

Read this statement from a website.

Immediately after the 'big bang', at the start of the Universe, there were only atoms of the element hydrogen (H).

Now the Universe contains atoms of over one hundred elements.

(a) Explain how atoms of the element helium (He) are formed in a star.

(2)

(b) Explain how atoms of very heavy elements, such as gold (Au), were formed.

(2)

(c) Explain how, and when, atoms of different elements may be distributed throughout the Universe.

.....  
.....  
.....  
.....

(2)  
(Total 6 marks)

Sample Question 23

Stars do not stay the same forever.

(a) Over billions of years the amount of hydrogen in a star decreases. Why?

.....  
..... (1)

(b) Describe how a massive star (at least five times bigger than the Sun) will change at the end of the main stable period. To gain full marks in this question you should write your ideas in good English. Put them into a sensible order and use the correct scientific words.

.....  
.....  
.....  
.....  
.....  
.....  
.....  
..... (4)

(c) The inner planets of the solar system contain atoms of the heaviest elements.

(i) Where did these atoms come from?

.....  
.....

(1)

(ii) What does this tell us about the age of the solar system compared with many of the stars in the Universe?

.....  
(1)  
(Total 7 marks)

### How science works

When carrying out experiments and answering questions based on interpreting experiment you need to know the following.

The independent variable is what is changed during an experiment

Remembering Tip: Independent starts with I so it is the variable that I change

The dependent variable is what you measure in the experiment i.e. the results

The control variables are the things you want to keep the same during an experiment.

During experiments we repeat measurements to make the results more reliable.

When plotting a graph for your results you generally plot the dependent variable along the y-axis and the independent variable along the x-axis.

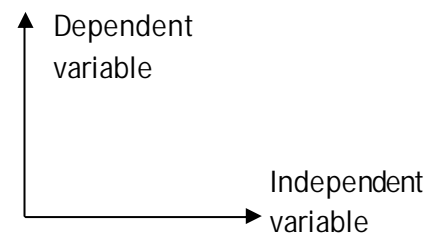

Your independent/dependent variable can either be continuous or categoric.

Continuous variables are numbers 1.2, 5.76, 3.0 etc – draw a line graph

Categoric variables are categories e.g. colours, metals – draw a bar chart

### Describing results

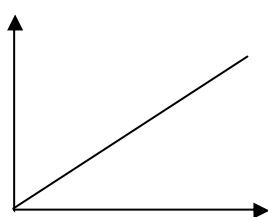

- This graph is showing a positive correlation, i.e. as one variable increases so does the other and the line goes up.
- A negative correlation is when one variable goes up the other goes down, the line would go downwards.

### Experimental procedure

Prediction: What you think will happen

Plan: How you are going to carry out your experiment

Conclusion: What you have found out from the experiment

Fair test: When you make sure each experiment is set up the same way

## SOLUTIONS TO EXAM QUESTION

### Question 1

(a)(i)	a single force that has the same effect as all the forces combined	accept all the forces added / the sum of the forces / overall force	1
(ii)	constant speed (in a straight line) or constant velocity	do <b>not</b> accept stationary	1
(b)	3	allow <b>1</b> mark for correct substitution into transformed equation accept answer 0.003 gains <b>1</b> mark answer = 0.75 gains <b>1</b> mark	2
	$\text{m/s}^2$		1
(c)	as speed increases air resistance increases	accept drag / friction for air resistance	1
	reducing the resultant force		1

### Question 2

question	answers	extra information	mark
7(a)	4.2	2 marks for correct substitution <b>and</b> transformation, ie 1155/275  allow <b>1</b> mark for correct resultant force with a subsequent incorrect method, ie 1155  allow <b>1</b> mark for an incorrect resultant force with a subsequent correct method, eg answers of 7.27 or 10.34 gain <b>1</b> mark	3

### Question 3

(a)	4	allow 1 mark for extracting correct information 12	2
	m/s <sup>2</sup>	ignore negative sign	1
(b)	9 (s)		1

### Question 4

question	answers	extra information	mark
5(a)	48	allow for 1 mark correct method shown, ie $6 \times 8$ or correct area indicated on the graph	2
5(b)	diagonal line from (0,0) to (6,48) / (6, their (a))	if answer to (a) is greater than 50, scale must be changed to gain this mark	1
	horizontal line at 48m between 6 and 10 seconds	accept horizontal line drawn at their (a) between 6 and 10 seconds	1

### Question 5

- (a) (i) tiredness / boredom  
drugs  
alcohol  
distraction  
*any two for 1 mark each*  
2

- (ii) A greater / longer  
B no effect  
C greater / longer  
*each for 1 mark*  
3

- (b) on a wet road: there is less friction / grip  
*for 1 mark*

braking distance is greater / takes longer to stop or car skids / slides forward  
*for 1 mark*

- (c) (i) deceleration = gradient or  $30 / 4.8$   
*each for 1 mark* 2
- (ii) force = mass  $\times$  acceleration or  $900 \times 6.25$   
*each for 1 mark* 2
- (iii) distance = area under graph or  
 $0.5 \times 4.8 \times 30$  or average speed  $\times$  time or  $15 \times 4.8$
- Accept answer in terms of change in k.e. = work done  
 if incorrect unit given (eg 72km) then no mark  
 each for 1 mark*

2

[13]

Question 6

- (a) gravity *accept weight  
 do **not** accept mass  
 accept gravitational pull* 1
- (b) (i) Initially force L greater than force M  
*accept there is a resultant force downwards* 1
- (as speed increases) force M increases  
*accept the resultant force decreases* 1
- when  $M = L$ , (speed is constant)  
*accept resultant force is 0  
 accept gravity/weighty for L  
 accept drag/upthrust/resistance/friction for M  
 do **not** accept air resistance for M but penalise only  
 once* 1
- (ii) terminal velocity 1
- (iii) 0.15  
*accept an answer between 0.14 – 0.16  
 an answer of 0.1 gains no credit  
 allow 1 mark for showing correct use of the graph*

## Question 7

- (a) **B** or bungee cords 1
- C** or springs or playground ride 1
- will go back to original shape/size 1
- (b) (i) newton 1
- (ii) 0 – 5 (N) or 5  
*accept 1 – 5 (N)*  
*do **not** accept 4* 1
- (iii) 16 (cm) 1
- (iv) 2.5 (N)  
*accept answer between 2.4 and 2.6 inclusive* 1

[7]

## Question 8

5(a)	47250	answers of 1350/ 33750/ 48600 gain 1 mark allow 1 mark for correct substitution using both 18 and 3	2
5(b)(i)	47250 or their (a)	accept statement 'same as the KE (lost)' ignore any units	1
5(b)(ii)	transformed into heat/ thermal energy	sound on its own is insufficient accept transferred/ lost/ for transformed do <b>not</b> accept any other form of energy included as a list	1





### Question 9

(a)	4 (m/s)	1 mark for correct transformation of either equation 1 mark for correct substitution with or without transformation 1 mark for correct use of 0.6N max score of 2 if answer is incorrect	3
(b)	greater change in momentum or greater mass of air (each second) or increase in velocity of air force upwards increased or force up greater than force down	accept speed for velocity lift force is increased do not accept upthrust accept weight for force down	1       1

### Question 10

- (a) (i) Ends have charge  
Which is opposite on each rod 2
- (ii) Attracts 1
- (b) (i) Repulsion 1
- (ii) Ends have same charge 1
- (c) Electrons move between cloth and rod  
Where material that gains electrons becomes negative  
Where material that loses electrons becomes positive 3

## Question 11

question	answers	extra information	mark
(a)(i)	ammeter symbol correct and drawn in series	accept 	1
	voltmeter symbol correct and drawn in parallel with the material	do not accept lower case a do not accept 	1
(ii)	adjust / use the variable resistor or change the number of cells	accept change the resistance  accept battery for cell accept change the p.d / accept change the voltage accept increase / decrease for change	1

## Question 12

3(a)(i)	30	allow 1 mark for showing correct method i.e. $5 \times 6$ or $12 \div 0.4$	2
3(a)(ii)	connected in <u>series</u>	insufficient they are not connected in parallel	1
3(a)(iii)	0.4		1
3(a)(iv)	equally/ evenly	the same is insufficient allow credit for candidates that correctly mention pd across the connecting wires  accept (nearly) 2V (each)	1

### Question 13

	answers	extra information	mark
(a)(i)	4 (V)	allow 1 mark for correct substitution	2
(ii)	5 (V) or (9 – their (a)(i)) correctly calculated	e.c.f do not allow a negative answer	1

### Question 14

(a) 50 hertz 1

(b) (i) a flow of charge / electrons 1

(ii) a.c. is constantly changing direction 1

whilst d.c. always flows in the same direction 1

(c) (i) 46.9

*accept 47.0*

*allow 1 mark for correct transformation and substitution*

*ie  $\frac{10800}{230}$*  2

(ii) current (46.9 A) exceeds maximum safe current for 2.5 mm<sup>2</sup> cable

*accept cable needs to be 16.0 mm<sup>2</sup>* 1

therefore if a 2.5 mm<sup>2</sup> cable were used it would overheat / melt  
*cable needs to be 10.0 mm<sup>2</sup> limits maximum credit to 1 mark* 1

(iii) can be reset 1

disconnects circuit faster (than a fuse) 1

[10]

## Question 15

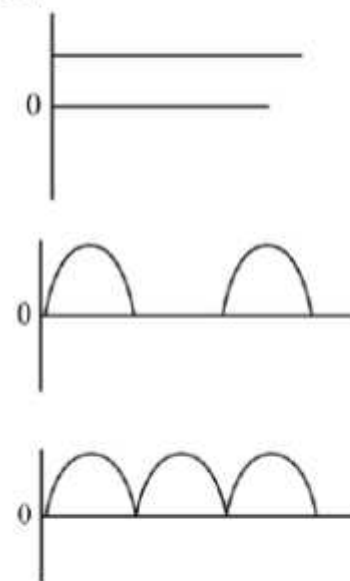
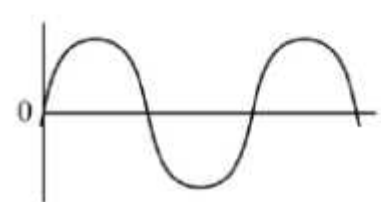
<p>5(a)</p>	<p>d.c. flows in (only) one direction</p> <p>a.c. <u>changes</u> direction (twice every cycle)</p>	<p>accept a.c. constantly changing direction</p> <p>ignore references to frequency</p> <p>accept answers presented as a clear diagram</p> <p>e.g.</p> <p>dc:</p>  <p>ac:</p> 	<p>1</p> <p>1</p>
<p>5(b)(i)</p>	<p>10</p>	<p>allow <b>1</b> mark for correct transformation and substitution</p> <p>i.e. <math>\frac{2.3}{230}</math> or <math>\frac{2300}{230}</math></p> <p>an answer 0.01 gains <b>1</b> mark</p>	<p>2</p>
<p>5(b)(ii)</p>	<p>13 A</p>	<p>e.c.f.</p> <p>accept the fuse size that is the next listed value greater than answer (b)(i)</p>	<p>1</p>

## Question 16

6(a)(i)	0.0046	<p>accept 4.6mA</p> <p>allow 1 mark for correct substitution and transformation</p> <p>i.e. current = <math>\frac{230}{50\,000}</math></p> <p>an answer of 4.6 gains 1 mark</p>	2
6(a)(ii)	<ul style="list-style-type: none"> <li>increases overall resistance</li> <li>(in event of a shock) gives a smaller current</li> </ul>	<p>accept gives smaller shock</p> <p>do <b>not</b> accept no shock/current</p>	1 1
6(b)(i)	50 (hertz)	ignore units	1
6(b)(ii)	<p>NO</p> <p>has the lowest current at which people cannot let go</p> <p>or</p> <p>YES</p> <p>changing the frequency changes the current by only a small amount</p>	<p>answer and reason needed</p> <p>accept a sensible reason in terms of their answer to (b) (i)</p>	1
6(c)	<p>a current flows through from the live wire/metal case to the earth wire</p> <p>this current causes the fuse to melt</p>	<p>accept a current flows from live to earth</p> <p>do <b>not</b> accept on its own if the current is too high</p> <p>accept blow for melt</p>	1 1

## Question 17

question	answers	extra information	mark
(a)(i)	3 fewer neutrons	accept fewer neutrons  accept different number of neutrons do <b>not</b> accept different number of electrons	1
(a)(ii)	electron from the nucleus	both points needed	1
(a)(iii)	32 (days)	allow <b>1</b> mark for clearly obtaining 4 half-lives	2
(a)(iv)	has a <b>much</b> longer half-life	accept converse answers in terms of iodine-131  accept it has not reached one half-life yet	1  1
	little decay happened / still in the atmosphere	accept it is still decaying	

## Question 18

question	answers	extra information	mark
4(a)(i)	(atoms / elements with) the same number of protons but different numbers of neutrons	accept (atoms / elements with) different mass number but same atomic number	1
4(a)(ii)	substances that give out radiation	accept alpha, beta or gamma for radiation accept an unstable nucleus that decays radioactive decay takes place is insufficient	1
4(b)	85 years	$\pm 2$ years  allow <b>1</b> mark for showing correct method on the graph	2
4(c)(i)	a helium nucleus	accept 2 neutrons and 2 protons accept ${}^4_2\text{He}$ do <b>not</b> accept helium atom	1

4(c)(ii)	the rate of decay (of plutonium) decreases	accept fewer (plutonium) nuclei (to decay) accept radioactivity decreases	1
	less heat produced	do <b>not</b> accept energy for heat	1

### Question 19

1(a)	<table border="1"> <thead> <tr> <th>Particle</th> <th>Relative Mass</th> <th>Relative charge</th> </tr> </thead> <tbody> <tr> <td>Proton</td> <td>1</td> <td></td> </tr> <tr> <td>Neutron</td> <td></td> <td>0</td> </tr> </tbody> </table>	Particle	Relative Mass	Relative charge	Proton	1		Neutron		0	accept one, accept +1 do <b>not</b> accept -1 accept zero do <b>not</b> accept no charge/ nothing/ neutral unless given with 0	1
	Particle	Relative Mass	Relative charge									
	Proton	1										
Neutron		0										
		1										
1(b)	equal numbers/amounts of protons and electrons  protons and electrons have equal but opposite charge	accept protons charge +1 and electron charge -1  accept (charge on) proton cancels/balances (charge on) electron accept positive (charges) cancel out the negative(charges)  neutrons have no charge is neutral do <b>not</b> accept total charge of protons, electrons (and neutrons) is 0 unless qualified	1									
1(c)(i)	(3) fewer neutrons . . .	accept lower/ smaller mass number  do <b>not</b> accept different numbers of neutrons  any mention of fewer/more protons or electrons negates mark  accept answers in terms of U-238 providing U-238 is specifically stated i.e. U-238 has (3) more neutrons	1									
1(c)(ii)	neutron		1									

1(c)(iii)	(nuclear) fission	accept fision  do <b>not</b> accept any spelling that may be taken as fusion	1
-----------	-------------------	------------------------------------------------------------------------------------	---

### Question 20

(a)(i)	(nuclear) fission	accept fision providing clearly <b>not</b> <u>fusion</u>	1
(ii)	(released) neutrons are absorbed by further (uranium) <u>nuclei</u>	accept hit <u>nuclei</u> for absorbed / hit do <b>not</b> accept atom for nuclei	1
	<u>more neutrons</u> are released (when new nuclei split)	accept for <b>both</b> marks a correctly drawn diagram	1
(iii)	increases by 1 or goes up to 236		1
(b)	any <b>two</b> from:		2
	• (more) neutrons are absorbed	accept there are fewer neutrons	
	• (chain) reaction slows down / stops	accept keeping the (chain) reaction controlled	
	• less energy released	accept heat for energy accept gases (from reactor) are not as hot	
4(d)(i)	(outside the body)  alpha (particles) cannot penetrate into the body		1
	(inside the body)  (heat produced from decay) damages / kills cells / tissues	accept causes cancer for damages / kills cells / tissues  accept <b>highly</b> toxic	1



4(d)(ii)	<p>any <b>one</b> from:</p> <ul style="list-style-type: none"> <li>• worried same could happen again</li> <li>• an accident may cause radiation to be spread around the Earth / atmosphere</li> <li>• idea of soil contamination resulting from accident / release of radioactive material</li> <li>• idea of negative effect on health resulting from accident / release of radioactive material</li> </ul>	1
		accept any sensible suggestion

Question 21

- (a) (i) gases (1)  
gravity (1)  
*correct order essential for credit* 2
- (ii) fusion 1
- (iii) billions 1
- (b) Milky Way 1

[5]

Question 22

- (a) fusion (1)  
of hydrogen/H (atoms)(1)  
do **not** credit any response which looks like 'fission' **or** the 'word' 'fussion'  
credit only if a nuclear reaction 2
- (b) fusion of other/lighter atoms/elements (1)  
reference to big bang nullifies both marks
- during super nova/explosion of star(s) (1) 2

(c) explosion of star(s)/super nova (1)  
*reference to big bang nullifies both marks reference to the star running out of energy/material nullifies both marks*

at the end of the 'life' of star(s) / when they 'die' (1)

2  
[6]

Question 23

(a) converted into helium  
*accept helium created*  
*accept converted into heavier elements*  
*accept used up in nuclear fusion / to produce energy*  
*do **not** accept any reference to burning*

1

(b) turns / expands into a red giant  
*contradictions negate mark*

1

contracts **and** explodes **or** becomes a supernova

1

may form a (dense) neutron star **or** (if enough mass shrinks to) form a black hole

*accept forms a neutron star and (then) a black hole*

1

**Quality of written communication**

*correct points must be in sequence*

1

(c) (i) supernova **or** remains of an earlier star  
*ignore super nebula*

1

(ii) younger **or** not formed at the time of the Big Bang

1

[7]